

# PIPESCAN™ HD

Mapping the Unseen.

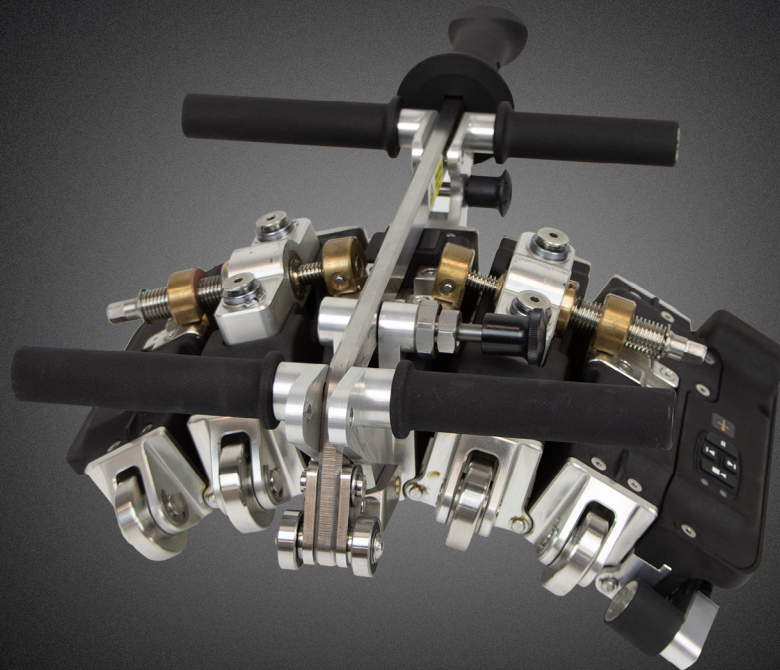

# SIMPLE, EFFECTIVE, CORROSION MAPPING. INCREASING THE CONFIDENCE OF INSPECTIONS

The Pipescan™ HD solution is designed to maximize speed, reliability and confidence for detection of defects such as corrosion and pittings in ferrous pipes and surfaces.

The Pipescan HD is the highest resolution Magnetic Flux Leakage (MFL) scanner on the market. It increases the total efficiency of integrity assessment campaigns by enhancing the productivity of the inspection team, optimizing the workflow to include on-the-spot reporting, and providing the asset owner with verifiable, recorded data.

Pipescan setup is easy with the unique single curvature adjustment tool allowing for a rapid inspection setup.

No couplant or complicated gate settings are required, connect the Pipescan to the data acquisition instrument, enter inspection details, and the system is ready to go. Furthermore, all scanned data is automatically recorded and reports can be issued on the spot, giving asset owners immediate visibility on the health condition of their assets, enhancing productivity and efficiency.

## Features

- Speed: scanning, data analysis, and reporting
- Highest resolution on the market offering easy to understand C-scan imaging
- High probability of corrosion detection with defects down to 1 mm identified
- Full data recording with adjustable reporting threshold feature
- Simple in-service deployment: No couplant and minimal surface preparation required
- Easy to operate with minimum training required
- Flexible heads fit a full range of pipe and vessel sizes

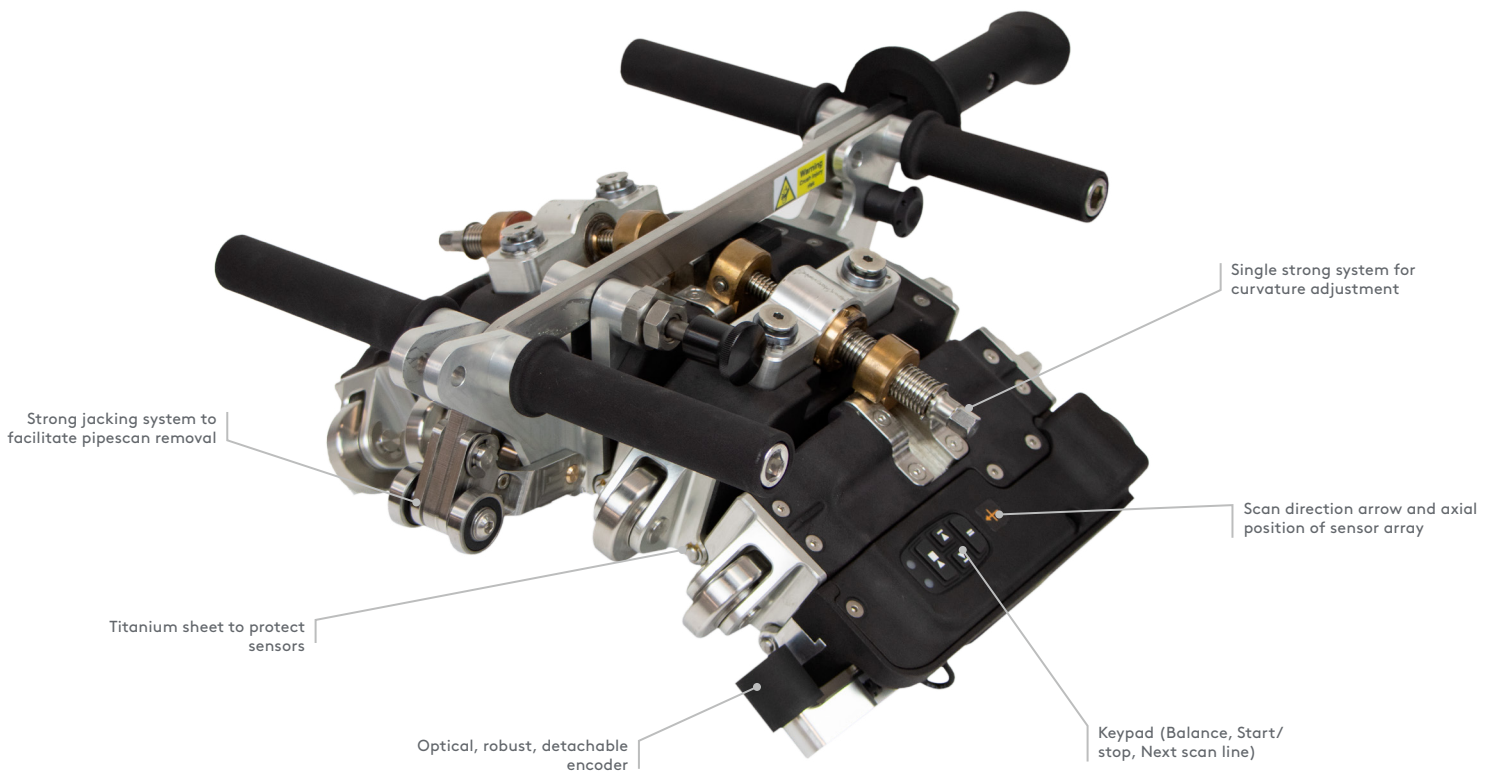

# PORTABLE, BATTERY-POWERED SOLUTION FOR RAPID CORROSION DETECTION WITH DATA COLLECTION

One-man operation, high Probability of Detection (PoD) compared to traditional spot readings, easy to understand results with minimal training.

## Adjustable Reporting Threshold

Keeping with the goal of a fast and easy to use solution, the software has retained the adjustable reporting threshold feature, allowing the user to only report on what is relevant to the work scope. As all the data is recorded, the reporting threshold can be adjusted post-inspection. By retaining all the data, engineers have the knowledge to make reliable maintenance decisions.

## Report on the go

Efficiency tools include a one-click reporting tool designed to improve the overall workflow from inspection to report. Indications can be analyzed on the go, at the end of a scan or the end of a job. Once the analysis has been completed, simply select "generate report", then transfer to a USB for distribution. Once the inspection is finished, so is the report.



# SPECIFICATIONS

## PIPESCAN PERFORMANCE

	PS-HD-MFL-127XFLAT	PS-HD-MFL-73X127	PS-HD-MFL-48X63
Technology	Magnetic Flux Leakage/Hall Effect Sensors		
Method of propulsion	Hand Push Speed up to 1 m/sec (40 in/sec)		
OD range (real value)	127 mm to flat (5.0 in to Flat)	73 mm to 127 mm (2.875 in to 5 in)	48 mm to 64 mm (1.9 in to 2.5 in)
Max recommended wall thickness	Up to 12.7 mm (0.5 in)	Up to 8.56 mm (0.337 in)	Up to 6.05 mm (0.238 in)
Maximum coating thickness	6 mm (non magnetic material)		
Number of channels	27	17	9
Channel spacing	7 mm (0.27 in)		
Smallest detectable defect	2 mm diameter defect at 10% wall loss		
Maximum surface temperature	60°C (140°F)		
Connecting cable	5 meter (15 feet) standard length		
Weight	30 lbs (13.4 Kg)	20.5 lbs (9.3 Kg)	12 lbs (5.5 kg)
Transit case	Meets IATA requirements for transporting magnetizable material		
Compatible Instruments	Silverwing Swift-M, Eddyfi Reddy-32M		

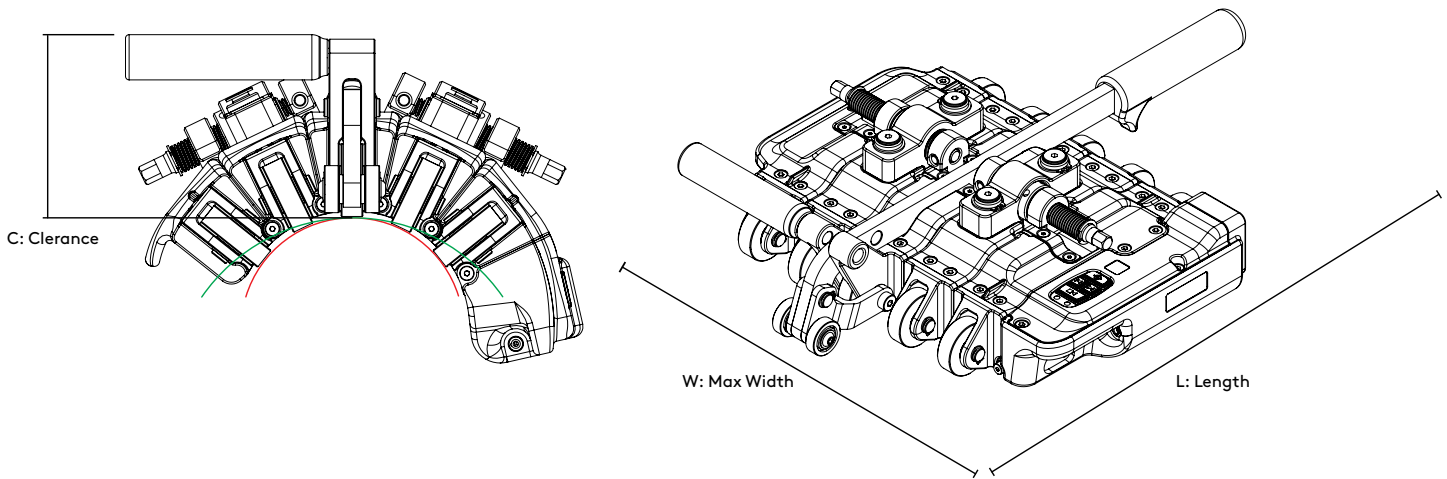

## DIMENSIONS

	PS-HD-MFL-127XFLAT	PS-HD-MFL-73X127	PS-HD-MFL-48X63
C: Profile Clearance	115 mm (4.5 in)	100 mm (4 in)	100 mm (4 in)
W: Maximum Width	317 mm (12.4 in)	242 mm (9.5 in)	173 mm (6.8 in)
L: Length	454 mm (17.8 in)	425 mm (16.7 in)	409 mm (16.1 in)

The information in this document is accurate as of its publication. Actual products may differ from those presented herein.  
 © 2021 Eddyfi UK Ltd. Eddyfi Technologies, Eddyfi, Silverwing, Swift, Reddy, Pipescan and their associated logos are trademarks or registered trademarks of Eddyfi Technologies (wholly owned subsidiary of Eddyfi NDT, Inc.) in Canada and/or other countries. Eddyfi Technologies reserves the right to change product offerings and specifications without notice.