

ROTIX

CE0106 Rev 04.4
Manual Chain Scanner

SAFETY WARNINGS / PRECAUTIONS

KEEP THIS MANUAL – DO NOT LOSE

THIS MANUAL IS PART OF THE **ROTIX** AND MUST BE RETAINED FOR THE LIFE OF THE PRODUCT. PASS ON TO SUBSEQUENT OWNERS.

Ensure any amendments are incorporated with this document.



DANGER! The **ROTIX** is designed for a specific use. Using the **ROTIX** outside of its intended use could cause damage to the product. Read and understand this manual before using.



WARNING! MAGNETIC MATERIAL. The wheels of this device produce a magnetic field which may cause failure or permanent damage to items such as watches, memory devices, CRT monitors, medical devices or other electronics.



People with pacemakers or ICD's must stay at least 25 cm (10 in) away at all times.



WARNING! Do **NOT** operate scanner in an explosive environment. Do **NOT** operate scanner in the presence of volatile substances.



The **WEEE** symbol indicates that the product must not be disposed of as unsorted municipal waste, but should be collected separately.

(see *Disposal* on page 43)

DISTRIBUTOR:

MANUFACTURER:

Jireh Industries Ltd.
53158 Range Road 224
Ardrossan, Alberta, Canada
T8E 2K4

Phone: (780) 922-4534
Fax: (780) 922-5766

jireh-industries.com

TABLE OF CONTENTS

| | | |
|----------|---|-----------|
| 1 | Introduction | 1 |
| | 1.1. Product information | 1 |
| | 1.1.1. Intended use | 1 |
| | 1.1.2. Performance specifications | 1 |
| | 1.1.3. Operating environment | 1 |
| | 1.1.4. Environmental Sealing | 1 |
| | 1.2. Definition of symbols | 1 |
| | 1.3. Hardware | 2 |
| | 1.3.1. Included tools | 2 |
| | 1.3.2. Optional tools | 2 |
| | 1.3.3. Maintenance | 2 |
| | 1.4. Chain Configuration Setup Chart | 3 |
| 2 | Configurations | 4 |
| | 2.1. One Probe, One Axis Encoding | 4 |
| | 2.2. Two Probe, One Axis Encoding | 4 |
| | 2.3. Four Probe, Two Axis Encoding | 5 |
| | 2.4. Single Probe, Two Axis Encoding with Single PPS | 5 |
| | 2.5. Two Probe, Two Axis Encoding with PPS | 6 |
| | 2.6. Four Probe, Two Axis Encoding with PPS | 6 |
| | 2.7. Single Probe, Two Axis Encoding with Slider PPS | 7 |
| | 2.8. Two Probe, Two Axis Encoding with Slider PPS | 7 |
| 3 | Operation | 8 |
| | 3.1. Setup of Rotix on Scanning Surface | 8 |
| | 3.2. Using a Probe Positioning System (PPS) | 10 |
| | 3.3. Using a Slider Probe Positioning System (Slider PPS) | 13 |
| 4 | System Components | 15 |
| | 4.1. Cart | 15 |
| | 4.1.1. Cart Body | 15 |
| | 4.1.2. Cart Handle | 15 |
| | 4.1.3. Brake Handle | 15 |
| | 4.1.4. Wheels | 16 |
| | 4.1.5. Umbilical Housing | 16 |

| | | |
|---------|---|----|
| 4.1.6. | Tail | 16 |
| 4.1.7. | Pivot Nose | 17 |
| 4.1.8. | Chain Mount | 17 |
| 4.1.9. | Frame Bar | 17 |
| 4.1.10. | Pivot Buttons | 18 |
| 4.2. | Chain Components | 18 |
| 4.2.1. | Chain Connection | 19 |
| 4.3. | Stabilizer Wheel | 19 |
| 4.3.1. | Installing a stabilizer wheel | 19 |
| 4.3.2. | Ratchet Lever | 20 |
| 4.4. | Probe Positioning System (PPS) | 21 |
| 4.4.1. | Installing a Probe Positioning System | 21 |
| 4.4.2. | Four Probe Setup | 22 |
| 4.4.3. | Index Encoding | 23 |
| 4.5. | Slip Joint Probe Holder | 24 |
| 4.5.1. | Probe Holder Setup | 24 |
| 4.5.2. | Probe Holder Adjustment | 26 |
| 4.5.3. | Probe Holder Force Adjustment | 26 |
| 4.5.4. | Slip Joint Probe Holder Left/Right Conversion | 28 |
| 4.6. | Cable Management System | 30 |
| 4.6.1. | Cable Management Dovetail Mount | 30 |
| 4.6.2. | Cable Management Setup | 31 |
| 4.6.3. | Clamp Setup | 32 |
| 4.7. | Reduced Width Scanning Kit | 32 |
| 4.8. | Vertical Probe Holder | 33 |
| 4.8.1. | Probe Holder Setup | 33 |
| 4.8.2. | Probe Holder Vertical Adjustment | 34 |
| 4.8.3. | Probe Holder Transverse Adjustment | 35 |
| 4.8.4. | Probe Holder Longitudinal Adjustment | 36 |
| 4.8.5. | Probe Holder Left/Right Conversion | 37 |
| 4.9. | Magnetic Wheel Kit | 39 |
| 4.10. | Single PPS | 39 |
| 4.11. | Slider Probe Positioning System | 40 |
| 4.11.1. | Slider PPS Assembly | 40 |
| 4.11.2. | Slider Index Encoding | 42 |
| 4.12. | Crank Handle | 42 |

5

Service and Support 43

| | | |
|------|-------------------|----|
| 5.1. | Troubleshooting | 43 |
| 5.2. | Technical Support | 43 |
| 5.3. | Disposal | 43 |

6

Spare Parts44

| | | |
|------|---|----|
| 6.1. | Rotix Cart | 44 |
| 6.2. | Chain Components | 46 |
| | 6.2.1. Encoder Connector Type | 47 |
| 6.3. | Probe Positioning | 47 |
| | 6.3.1. Probe Positioning System (PPS) | 47 |
| | 6.3.2. Slider Probe Positioning System (Slider PPS) | 48 |
| 6.4. | Probe Holders | 49 |
| | 6.4.1. Slip Joint Probe Holder Parts | 49 |
| | 6.4.2. Vertical Probe Holder Parts | 50 |
| 6.5. | Probe Holder Components | 51 |
| | 6.5.1. Arm Style | 51 |
| | 6.5.2. Yoke Style | 51 |
| | 6.5.3. Swing Arm Style | 51 |
| | 6.5.4. Pivot Button Style | 51 |
| 6.6. | Variable Components | 52 |
| | 6.6.1. Frame Bars | 52 |
| 6.7. | Accessories | 52 |
| | 6.7.1. Cable Management | 52 |
| | 6.7.2. Pre-Amp Bracket | 53 |
| | 6.7.3. Magnetic Wheel Kit | 53 |
| | 6.7.4. Reduced Width Scanning Kit | 53 |

7

Limited Warranty54

INTRODUCTION

1.1. Product information

1.1.1. Intended use

The **ROTIX** chain scanner is a manually operated dual axis encoded scanner. Its primary purpose is to move ultrasonic probes circumferentially around piping and tubes to provide encoded positional information (*second Y axis scanning is optional*).

1.1.2. Performance specifications

| | Minimum | Maximum |
|--|--------------------------------------|--------------------|
| Pipe/Tube Range | 38.1 mm (1.5 in) | 965.2 mm (38.0 in) |
| Umbilical Length (Standard Kit) | 5 m (16.4 in) | |
| X-Axis Encoder Resolution | 19.1 counts/mm (485.9 counts/inch) | |
| Y-Axis Encoder Resolution | 40.3 counts/mm (1023.9 counts/inch) | |
| Y-Axis Encoder Resolution (Slider PPS) | 161.3 counts/mm (4096.0 counts/inch) | |

1.1.3. Operating environment

The **ROTIX** Chain Scanner is designed for use in an industrial environment that is between -20°C (-4°F) and 50°C (122°F).

1.1.4. Environmental Sealing

Dust tight, water tight (not submersible).

1.2. Definition of symbols



Instructions to 'look here' or to 'see this part'

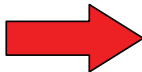

Denotes movement. Instructing user to carry out action in a specified direction.



Indicates alignment axis, can also indicate insertion or movement of parts.



Alerts user that view has changed to a reverse angle

1.3. Hardware

1.3.1. Included tools

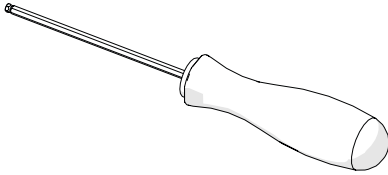

Fig. 1 - 3 mm hex driver

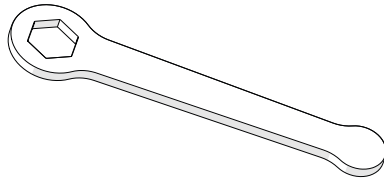

Fig. 2 - 3/8 in wrench

The 3 mm hex driver (*Fig. 1*) is sufficient for all typical operations and adjustments of the **ROTIX**. The 3/8 in wrench (*Fig. 2*) is used to remove and install buttons on the probe holders.

1.3.2. Optional tools

Some specialized adjustments require tools that are not included with this kit.

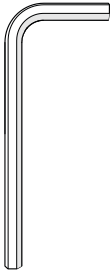

Fig. 3 - 1.5 mm hex wrench

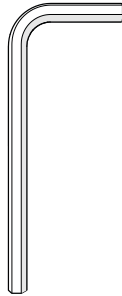

Fig. 4 - 2 mm hex wrench

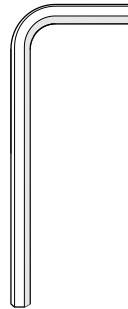

Fig. 5 - 2.5 mm hex wrench

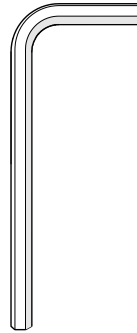

Fig. 6 - 3 mm hex wrench

1.3.3. Maintenance

General cleaning of components is important to keep your system working well. All components that have no wiring or cables are completely waterproof. Components can be washed with warm water, dish soap and a medium bristle brush.

After washing your system, use a light oil to lubricate the slide and the adjustment screw on the buckle component (*Fig. 49*). Before using the scanner, ensure all connectors are free of water and moisture.

NOTE: All components with wiring, cables or electrical connections are splash proof. However, these components are **NOT** submersible.

NOTE: Never use strong solvents or abrasive materials to clean your scanner components.

1.4. Chain Configuration Setup Chart

| PIPE SIZE | | | | LINKS | |
|--|----------|----------|----------|--------|------|
| MIN (in) | MAX (in) | MIN (mm) | MAX (mm) | SHORT* | LONG |
| *Short includes: Short Link, Dovetail Link, Red Catch Link 15 Ø Is possible by pivoting nose to horizontal position | | | | | |
| 2.1 | 3.0 | 53 | 76 | 1 | 0 |
| 3.0 | 3.9 | 76 | 99 | 2 | 0 |
| 3.9 | 4.8 | 99 | 122 | 3 | 0 |
| 4.9 | 5.8 | 124 | 147 | 4 | 0 |
| 5.8 | 6.6 | 147 | 168 | 5 | 0 |
| 6.6 | 7.5 | 168 | 191 | 6 | 0 |
| 7.4 | 8.3 | 188 | 211 | 7 | 0 |
| 8.3 | 9.1 | 211 | 231 | 8 | 0 |
| 9.1 | 10.0 | 231 | 254 | 9 | 0 |
| 10.0 | 10.8 | 254 | 274 | 7 | 1 |
| 10.8 | 11.6 | 274 | 295 | 8 | 1 |
| 11.5 | 12.4 | 292 | 315 | 9 | 1 |
| 12.7 | 13.5 | 323 | 343 | 1 | 4 |
| 13.5 | 14.3 | 343 | 363 | 2 | 4 |
| 14.2 | 15.0 | 361 | 381 | 3 | 4 |
| 15.0 | 15.8 | 381 | 401 | 4 | 4 |
| 15.8 | 16.7 | 401 | 424 | 2 | 5 |
| 16.6 | 17.4 | 422 | 442 | 3 | 5 |
| 17.3 | 18.2 | 439 | 462 | 4 | 5 |
| 18.2 | 19.0 | 462 | 483 | 2 | 6 |
| 19.0 | 19.8 | 483 | 503 | 3 | 6 |
| 19.7 | 20.6 | 500 | 523 | 4 | 6 |
| 20.5 | 21.3 | 521 | 541 | 5 | 6 |
| 21.2 | 22.1 | 538 | 561 | 6 | 6 |
| 22.0 | 22.9 | 559 | 582 | 7 | 6 |
| 22.8 | 23.7 | 579 | 602 | 8 | 6 |
| 23.6 | 24.5 | 599 | 622 | 9 | 6 |
| 24.5 | 25.4 | 622 | 645 | 1 | 9 |
| 25.3 | 26.1 | 643 | 663 | 2 | 9 |
| 26.1 | 26.9 | 663 | 683 | 3 | 9 |
| 26.8 | 27.7 | 681 | 704 | 4 | 9 |
| 27.7 | 28.5 | 704 | 724 | 2 | 10 |
| 28.4 | 29.3 | 721 | 744 | 3 | 10 |
| 29.2 | 30.1 | 742 | 765 | 4 | 10 |
| 30.0 | 30.9 | 762 | 785 | 2 | 11 |
| 30.8 | 31.6 | 782 | 803 | 3 | 11 |
| 31.6 | 32.4 | 803 | 823 | 4 | 11 |
| 32.4 | 33.2 | 823 | 843 | 2 | 12 |
| 33.2 | 34.0 | 843 | 864 | 3 | 12 |
| 33.9 | 34.8 | 861 | 884 | 4 | 12 |
| 34.7 | 35.6 | 881 | 904 | 5 | 12 |
| 35.5 | 36.4 | 902 | 925 | 6 | 12 |
| 36.3 | 37.2 | 922 | 945 | 7 | 12 |
| 37.1 | 38.0 | 942 | 965 | 8 | 12 |
| 37.9 | 38.8 | 963 | 986 | 9 | 12 |

CONFIGURATIONS

2.1. One Probe, One Axis Encoding

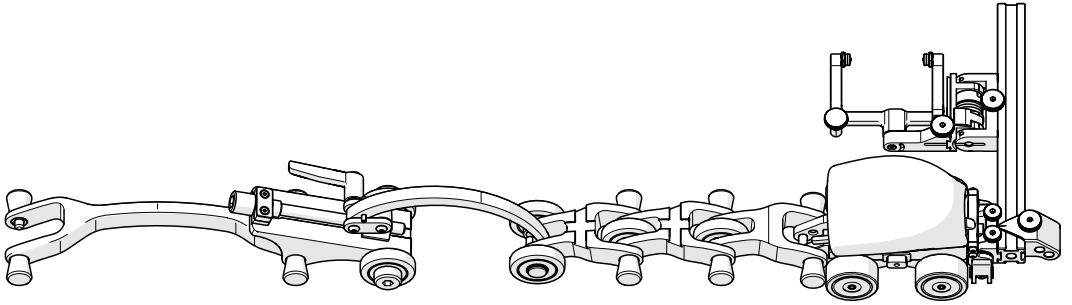

Fig. 7 - One probe, one axis encoding

2.2. Two Probe, One Axis Encoding

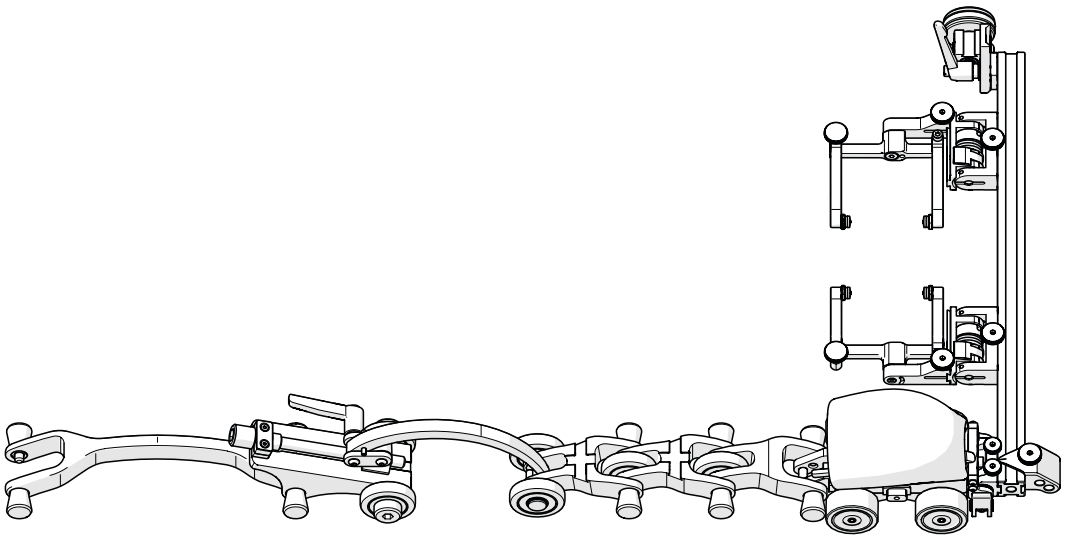

Fig. 8 - Two probe, one axis encoding

2.3. Four Probe, Two Axis Encoding

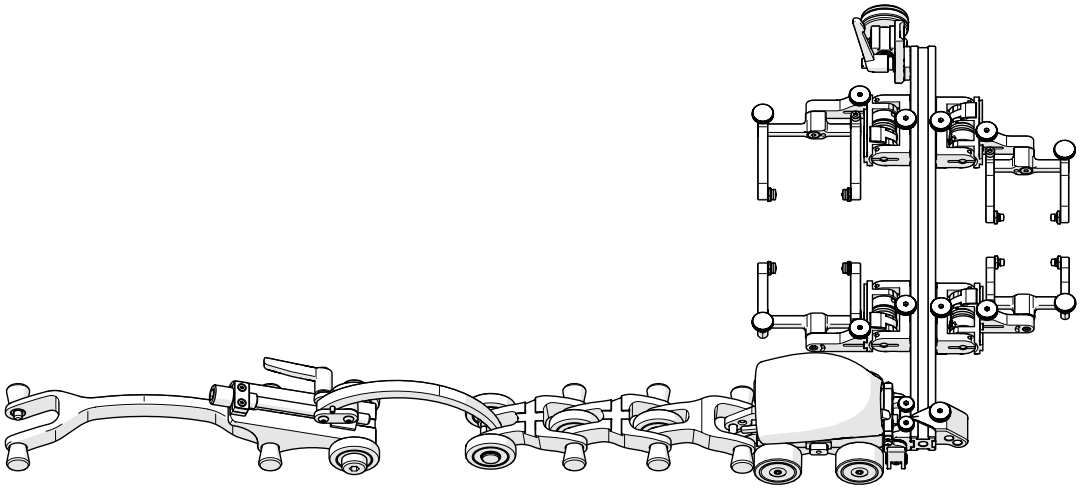

Fig. 9 - Four probe, one axis encoding

2.4. Single Probe, Two Axis Encoding with Single PPS (Probe Positioning System)

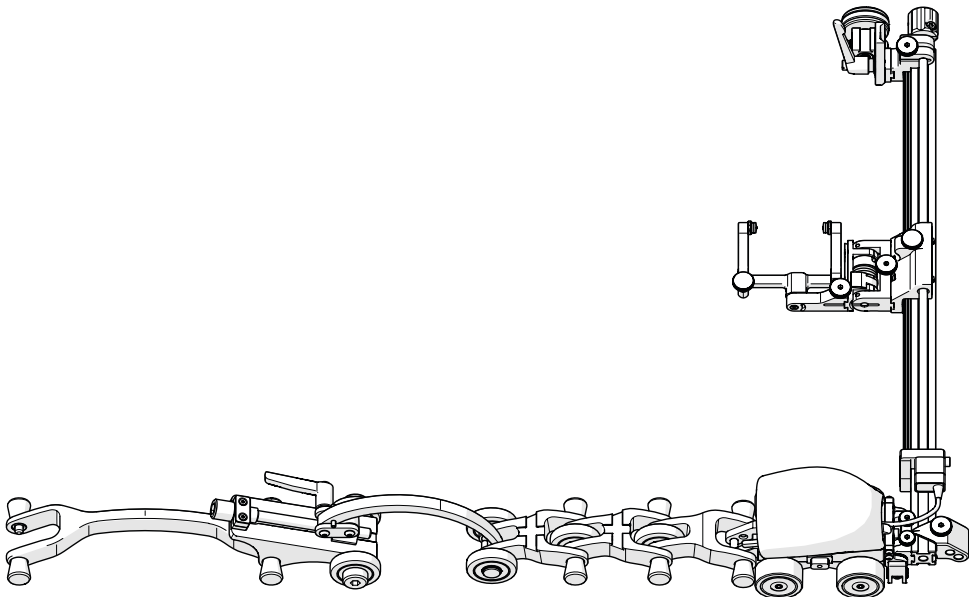

Fig. 10 - Single probe, two axis encoding with single PPS

2.5. Two Probe, Two Axis Encoding with PPS (Probe Positioning System)

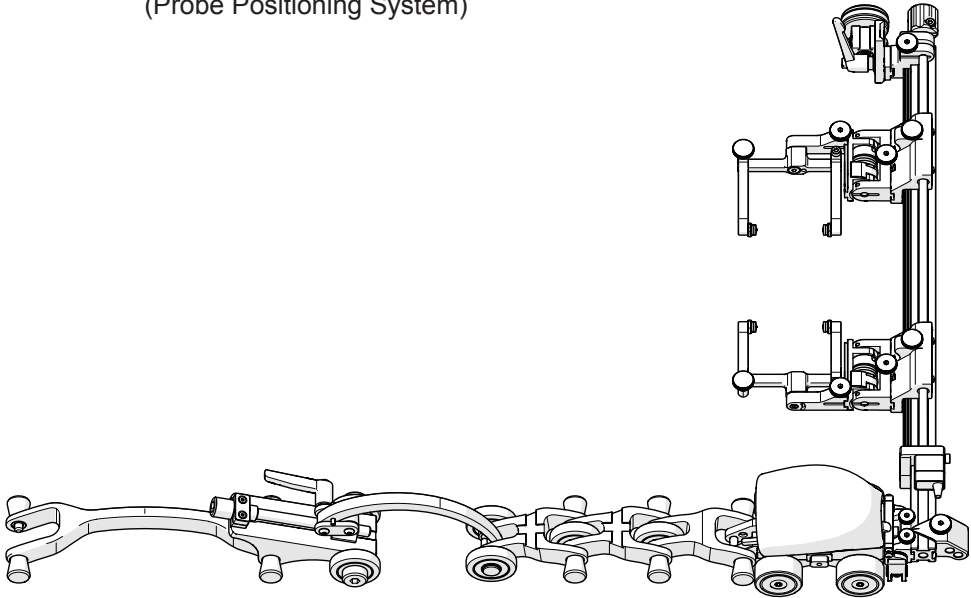

Fig. 11 - Two probe, two axis encoding with PPS

2.6. Four Probe, Two Axis Encoding with PPS (Probe Positioning System)

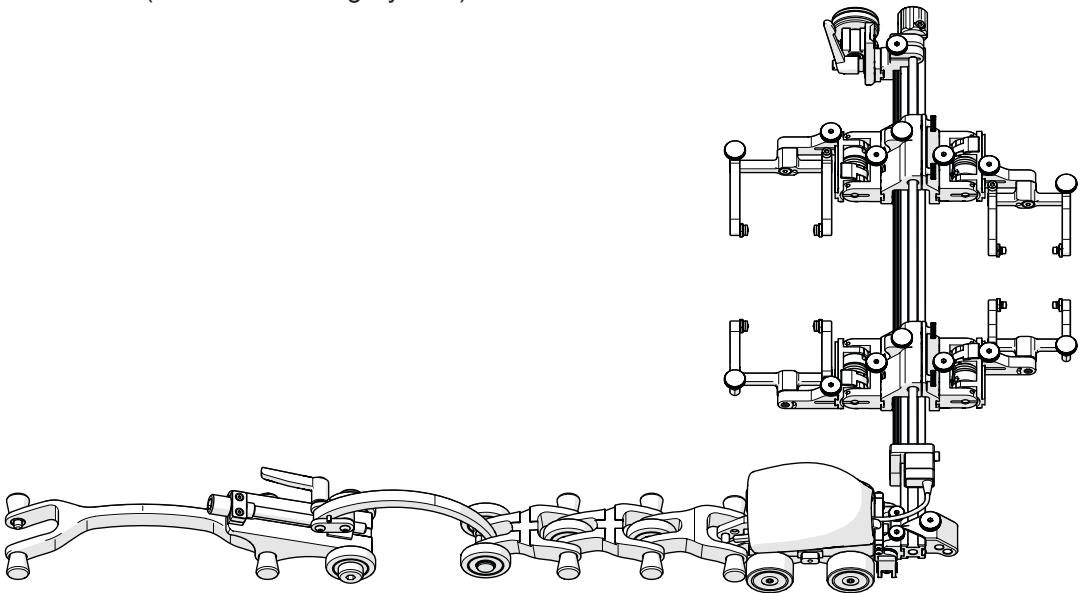

Fig. 12 - Four probe, two axis encoding with PPS

2.7. Single Probe, Two Axis Encoding with Slider PPS (Probe Positioning System)

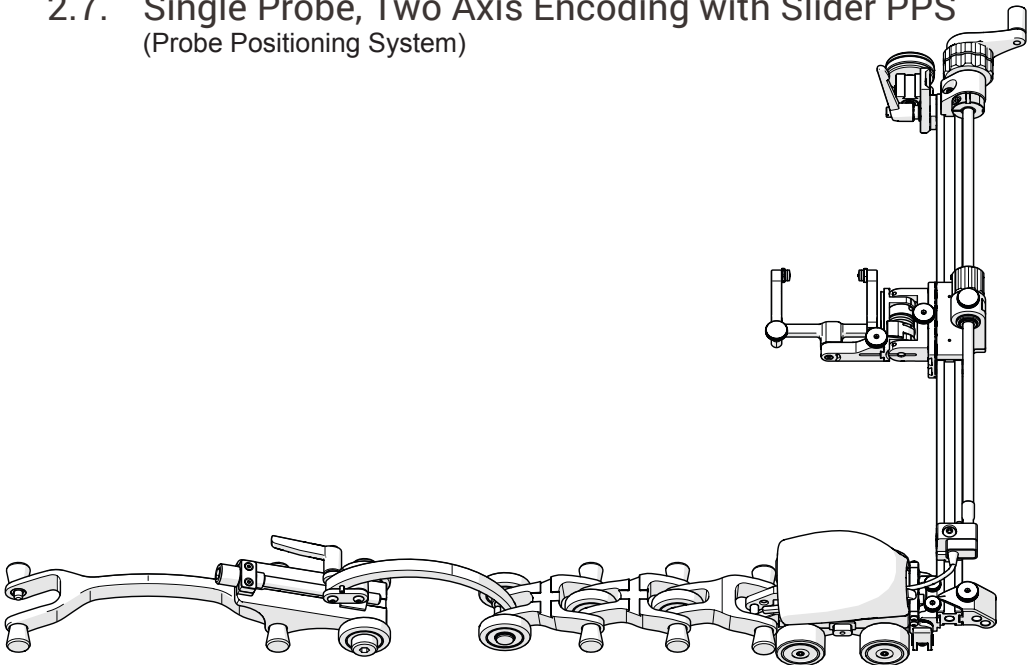

Fig. 13 - Single probe, two axis encoding with slider PPS

2.8. Two Probe, Two Axis Encoding with Slider PPS (Probe Positioning System)

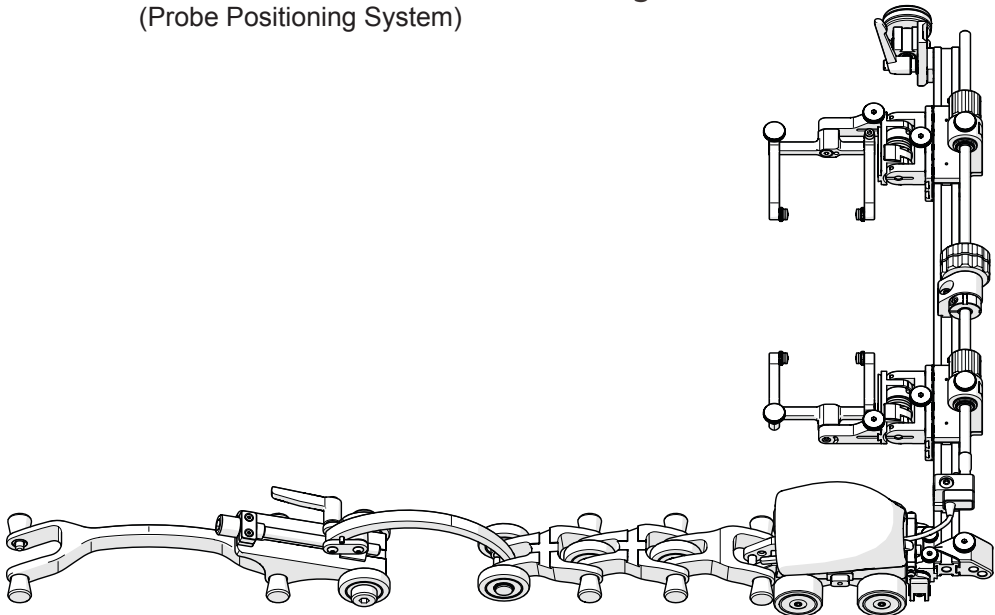

Fig. 14 - Two probe, two axis encoding with slider PPS

OPERATION

3.1. Setup of Rotix on Scanning Surface

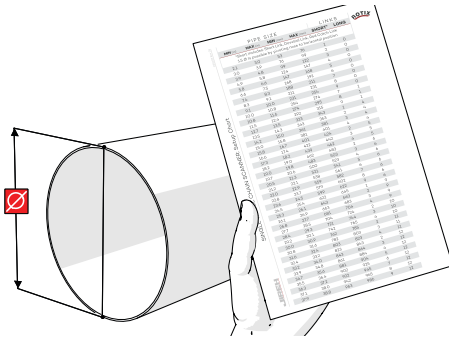

Fig. 15 - Refer to setup chart

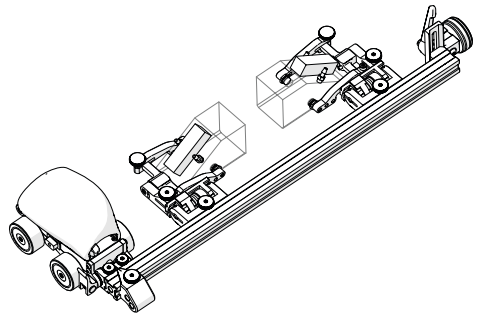

Fig. 16 - Assemble configuration

1. Determine the diameter of the pipe or tube to be scanned. Included in the **ROTIX** kit is a setup chart which will indicate the number of links required based on the diameter of the pipe or tubing (Fig. 15).
2. Assemble the appropriate configuration to the cart body (Fig. 16). Install the wedge and probes that will be used (see Slip Joint Probe Holder on page 24).

TIP: Route cables and hoses through the cart handle as a means of cable management to the cable management (see Cable Management System on page 30).

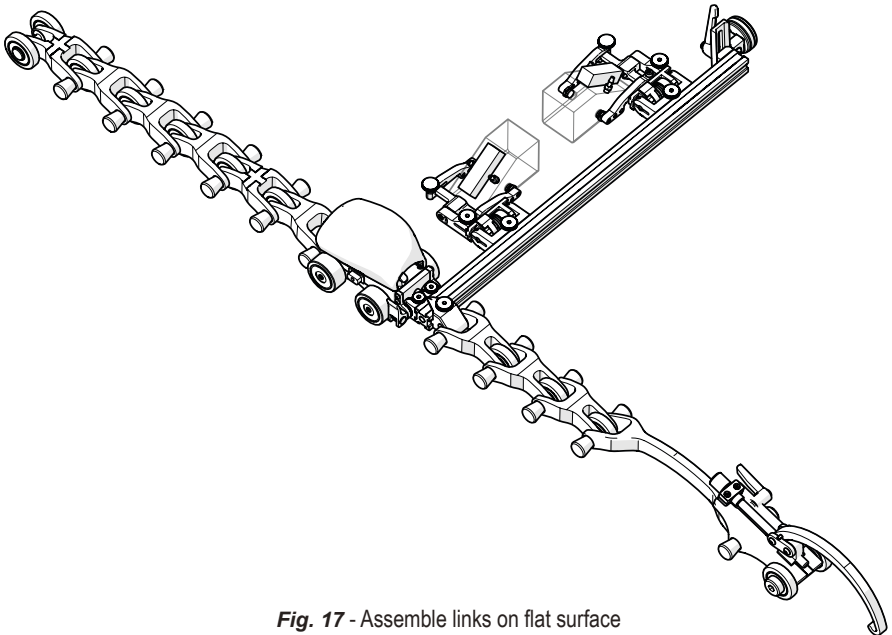

Fig. 17 - Assemble links on flat surface

TIP: This example provided is a two probe, one axis configuration for a 24 in pipe diameter.

3. On a flat surface, connect the appropriate amount of links as indicated on the **ROTIX** setup chart. Arrange the link setup so the buckle and catch link will be 180° opposite of the cart body (Fig. 17).

TIP: Place the dovetail link 2nd in the chain behind the cart body (Fig. 92 on page 30).

4. Ensure the cart's brake is locked (see *Brake Handle* on page 15).
5. Drape the configured assembly around pipe that will be inspected (Fig. 18).

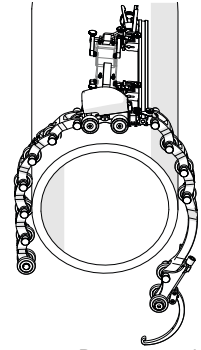

Fig. 18 - Drape onto pipe

TIP: Use caution when placing the assembly on the scan surface. The magnetized stabilizer wheel can lurch towards the metal suddenly.

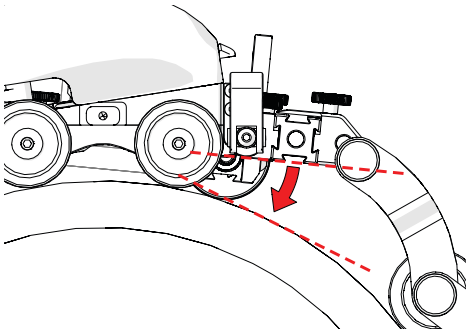

Fig. 19 - Lower pivot nose

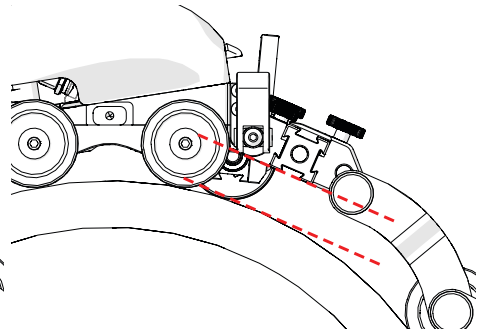

Fig. 20 - Parallel with scan surface tangent

6. Adjust the pivot nose (Fig. 19) angle to align the frame bar parallel with the tangent of the scan surface (Fig. 20).

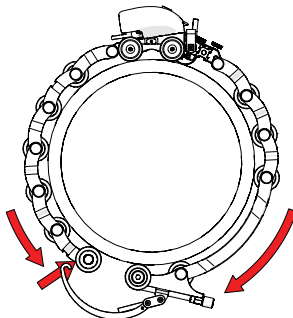

Fig. 21 - Hook buckle to catch link

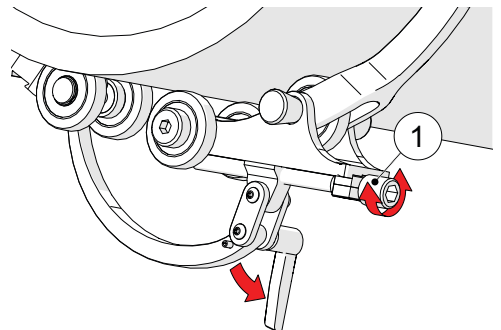

Fig. 22 - Adjust pressure of buckle

7. Bring the buckle arm towards the catch link. Hook the buckle's arm to the middle axle of the catch link (Fig. 21). The buckle adjustment knob (Fig. 22-1) may have to be loosened to allow arm to reach catch link.

8. Rotate the knob until the buckle's lever can be pushed down locking the buckle in place (Fig. 23). The tightness of the **ROTIX** on the pipe can be adjusted using the buckle adjustment knob (Fig. 22-1).

TIP: If additional clearance is needed, the handle on the buckle can be pulled out and rotated to various positions.

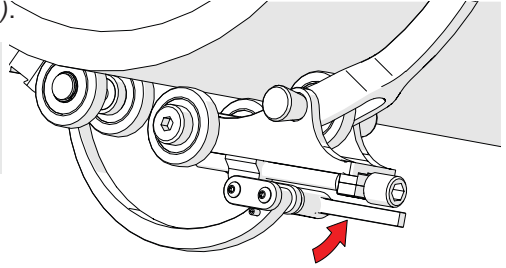

Fig. 23 - Press down to lock

9. Adjust the stabilizer wheel (Fig. 24) to align the frame bar parallel with the scan surface. (see Stabilizer Wheel on page 19).

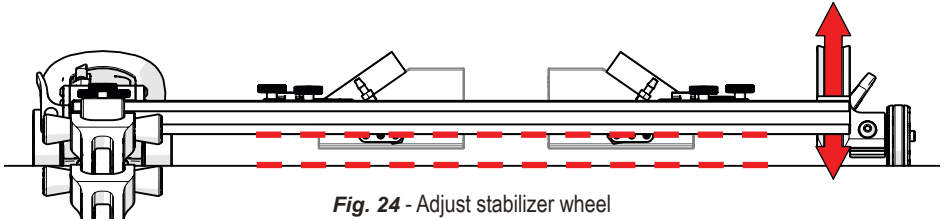

Fig. 24 - Adjust stabilizer wheel

10. Lower probes to the scanning surface (see Slip Joint Probe Holder on page 24).

3.2. Using a Probe Positioning System (PPS)

The probe positioning system uses a linear rail with leadscrew system to position two or four probes for weld inspection or one probe for corrosion scanning. To setup and install a probe positioning system (see *Installing a Probe Positioning System on page 21*).

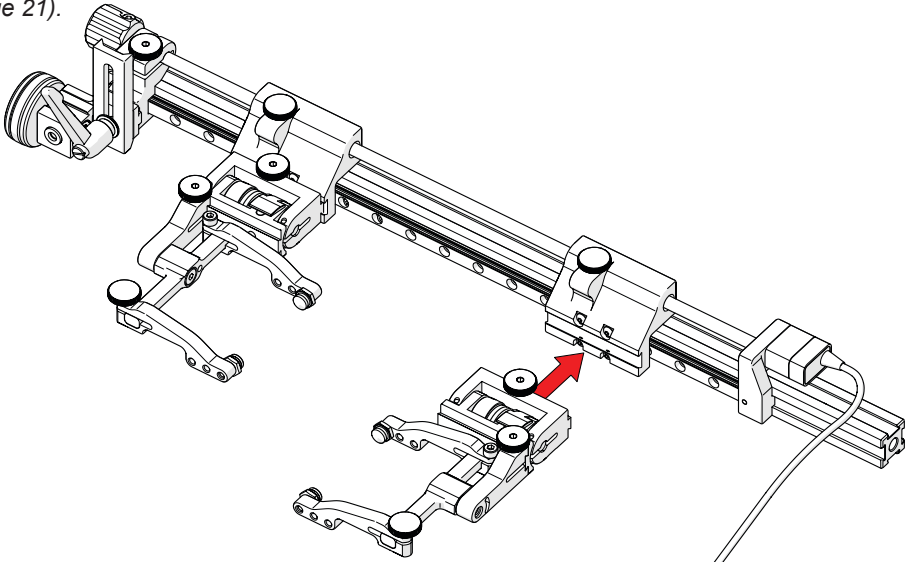

Fig. 25 - Mount probe holders

1. Attach the probe holders (see *Slip Joint Probe Holder* on page 24) to the carriage (Fig. 25).

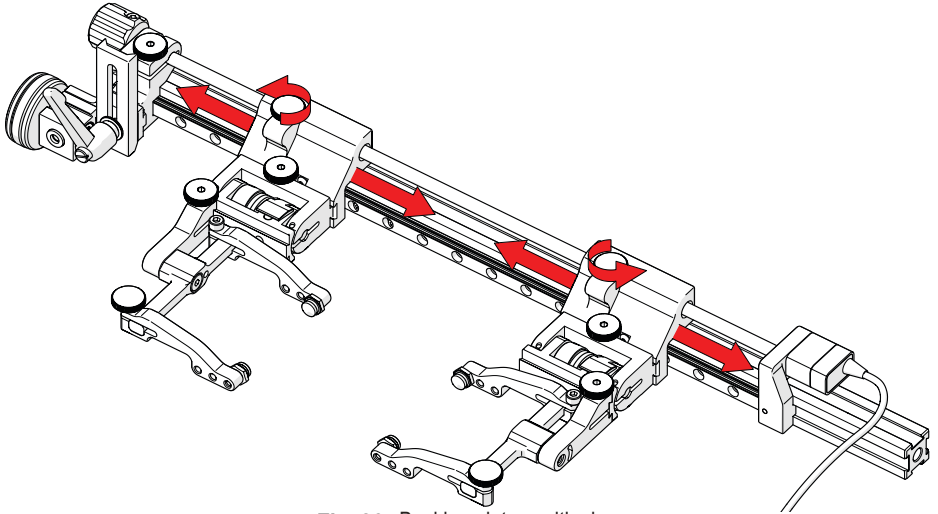

Fig. 26 - Backing plate positioning

2. The knob on the carriage allows for adjustment of the probe holders on the leadscrew (Fig. 26).

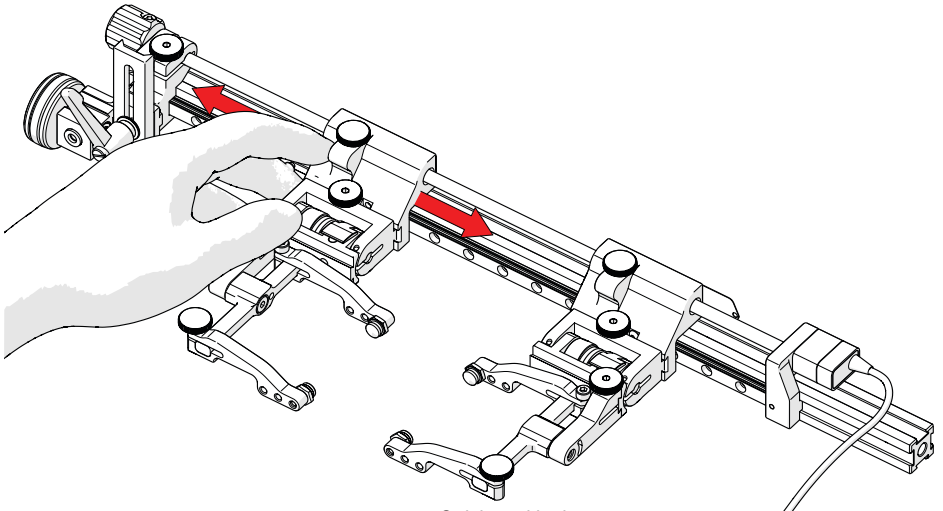

Fig. 27 - Quick positioning

3. When the knobs are loose, it is possible to just push the carriages in place for quick adjustment (Fig. 27). Tighten both knobs to lock the carriages in position.

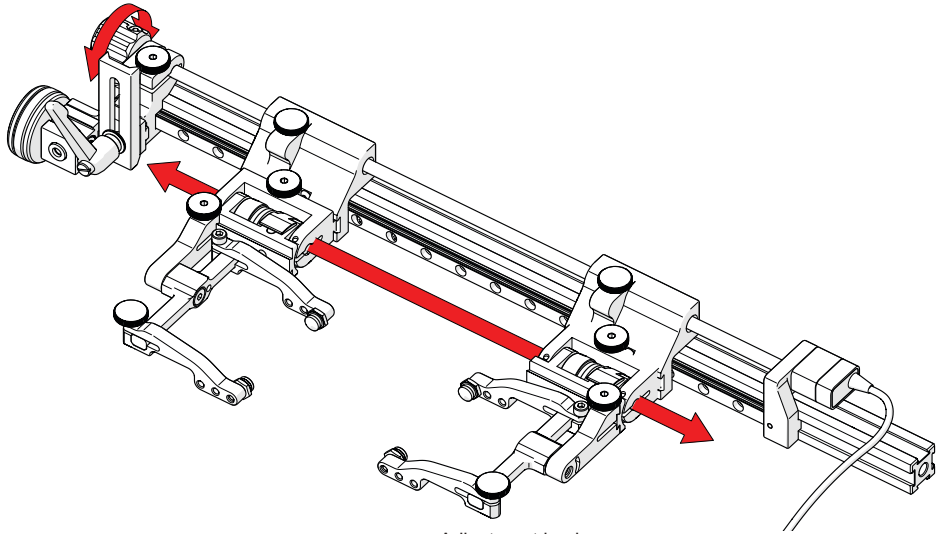

Fig. 28 - Adjustment knob

4. Ensure the leadscrew lock knob (Fig. 29) is loose. Use the PPS adjustment knob to position both carriages simultaneously (Fig. 28).

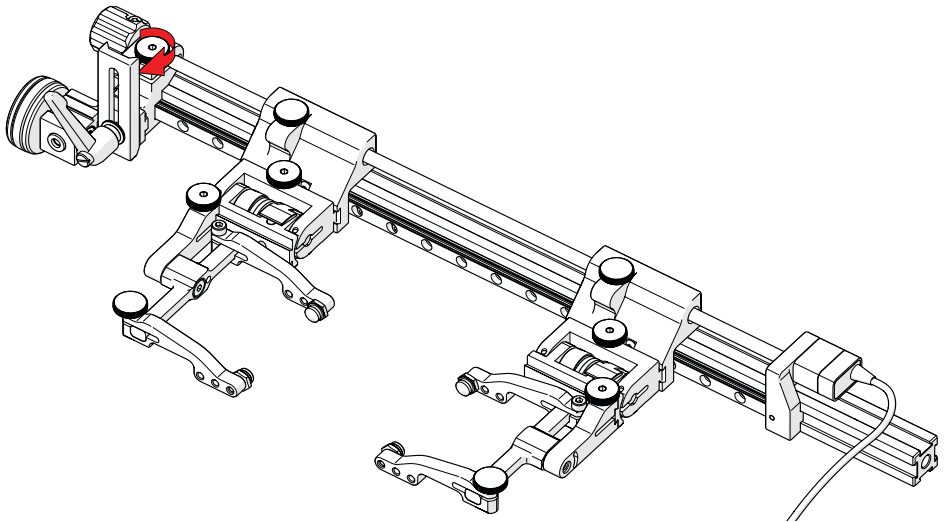

Fig. 29 - Position lock knob

5. The PPS lock knob prevents the leadscrew from movement once scanning is underway (Fig. 29).

3.3. Using a Slider Probe Positioning System (Slider PPS)

The slider probe positioning system uses a slide and leadscrew system to position one or two probes for weld inspection. To setup and install a slider probe positioning system (see *Slider PPS Assembly* on page 40)

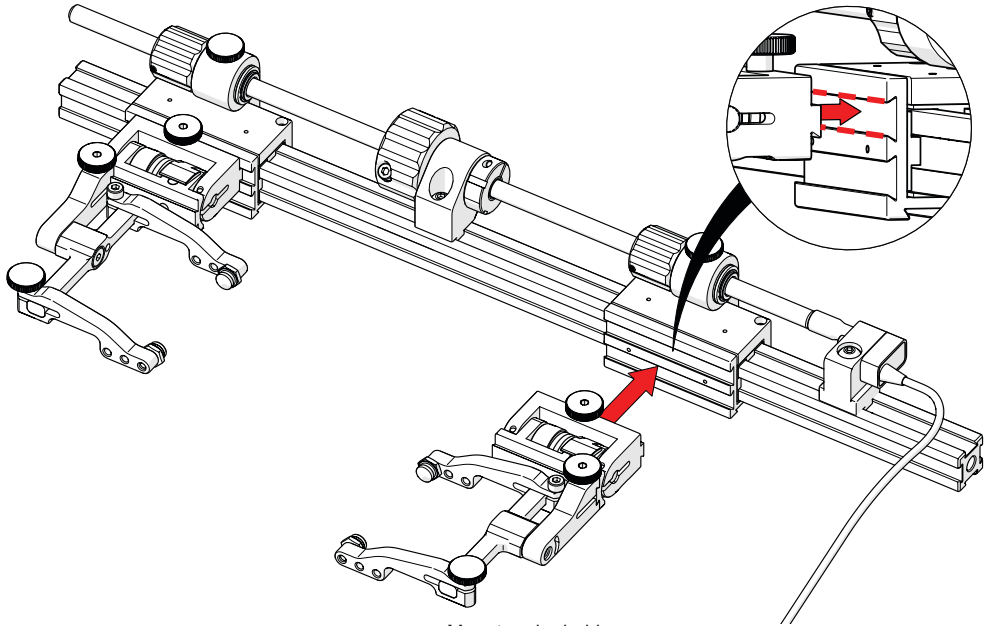

Fig. 30 - Mount probe holders

1. Attach the probe holders (see *Slip Joint Probe Holder* on page 24) to the top groove on the mounting bracket of the slider (Fig. 30).

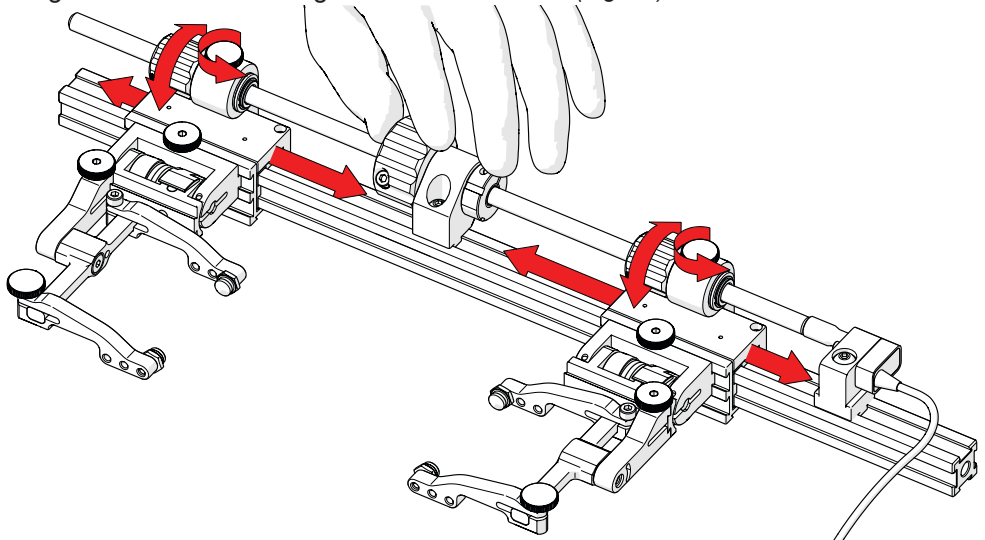

Fig. 31 - Individual slider positioning

2. Loosen the knob at the top of the slider. Rotate the small knobs allowing individual placement of the sliders (*Fig. 31*). The main knob must be held firm when rotating the small knobs for the correct movement to take place.

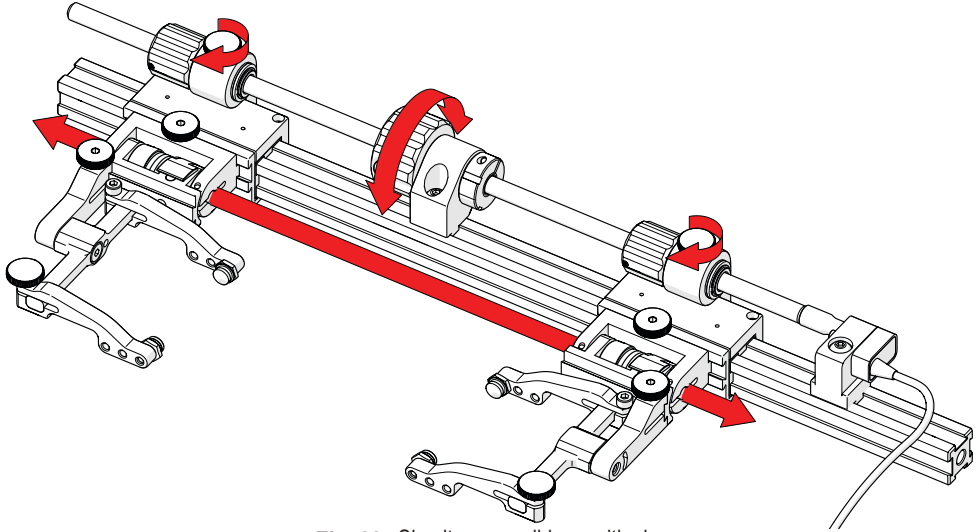

Fig. 32 - Simultaneous slider positioning

3. Ensure the slider knobs are tight and rotate the main knob to position both sliders simultaneously (*Fig. 32*).

SYSTEM COMPONENTS

4.1. Cart

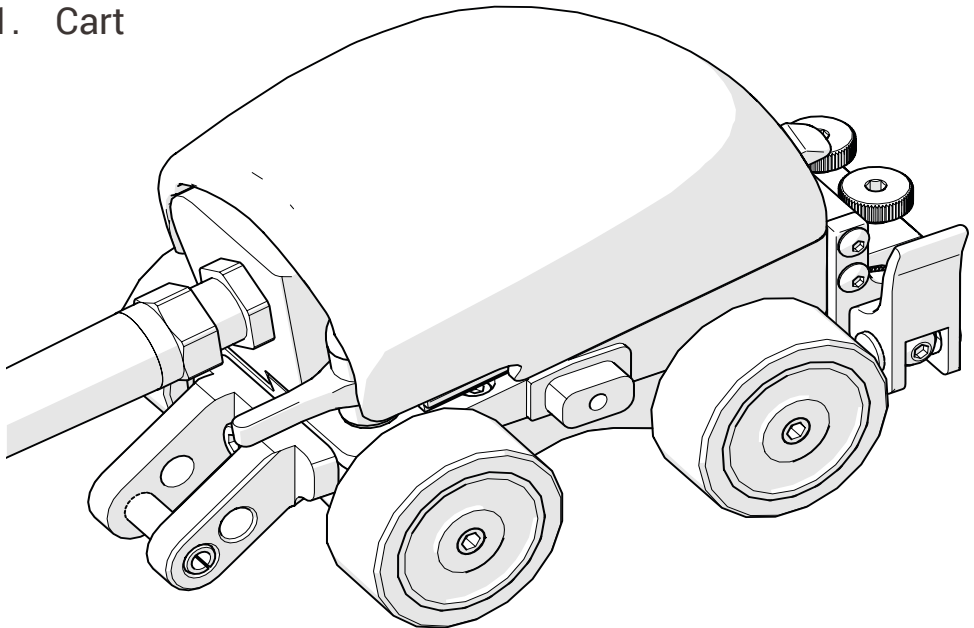

Fig. 33 - Scanner body

4.1.1. Cart Body

The housing for the main encoder and provides a mounting base for probe holders and the umbilical (Fig. 33).

4.1.2. Cart Handle

The handle is used to both manage cabling and provide an ergonomic grip during use.

To remove the cart handle, simultaneously depress the handle release catch and slide forward (Fig. 34).

4.1.3. Brake Handle

Pivot the brake handle left or right to engage or disengage the brake.

To remove the brake handle pull straight up (Fig. 35). Pull directly up as a side load will cause the brake to bind and will become difficult to remove. To reinsert, align the spline on the handle with the socket and press down.

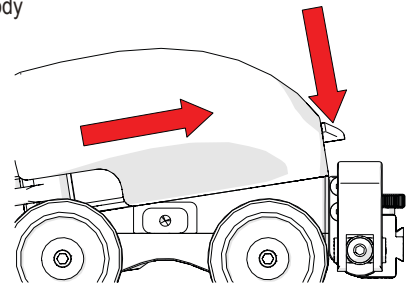

Fig. 34 - Cart handle removal

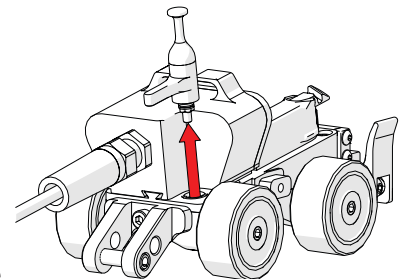

Fig. 35 - Brake handle removal

4.1.4. Wheels

The cart wheels are interchangeable. Urethane wheels provide smooth rolling but must be used with chain links. Optional magnetic wheels may be used in applications when a chain is not practical.

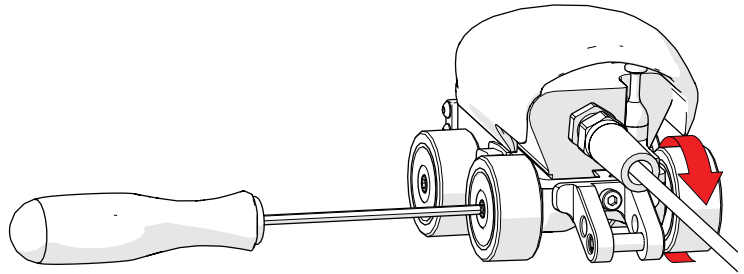

Fig. 36 - Wheel removal

To remove/install the cart wheels, insert the provided 3 mm hex driver (Fig. 1) in the end of the shaft opposite the wheel you wish to remove. Thread or unthread the desired wheel by hand (Fig. 36).

TIP: Be sure all wheels are tight as this can affect the brake and encoder performance.

4.1.5. Umbilical Housing

The umbilical transmits encoder signals to the user's instrument. The umbilical may be used for both one and two axis encoded scans.

To remove the umbilical, first remove the cart handle (Fig. 34) and brake handle (Fig. 35). Loosen the black wing knob one turn on the bottom of cart (Fig. 37).

With the knob loose, slide the umbilical housing towards the rear of the cart (Fig. 38).

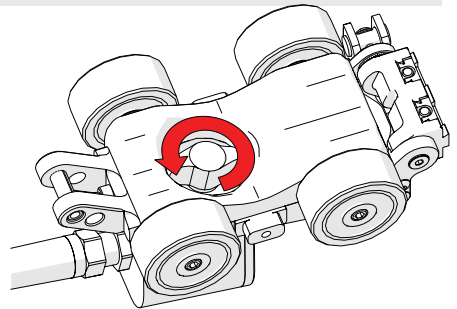

Fig. 37 - Umbilical housing lock knob

TIP: The umbilical lock knob is only required to be loose, one turn should be enough to remove the umbilical.

TIP: If the umbilical does not slide freely from the body, you may need to push on the wing knob to loosen the dovetail nut.

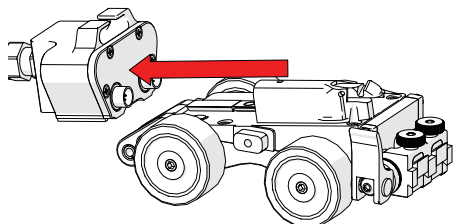

Fig. 38 - Umbilical housing removal

4.1.6. Tail

Located at the rear of the cart body. The tail provides a connection point for chain links (Fig. 39).

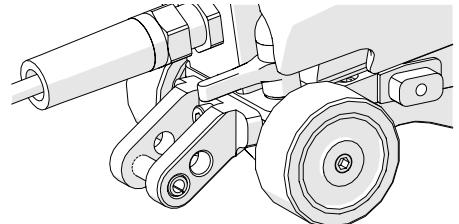

Fig. 39 - Tail

4.1.7. Pivot Nose

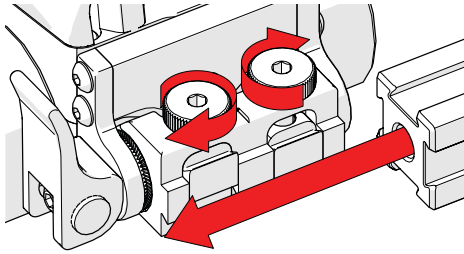

Fig. 40 - Frame bar attachment

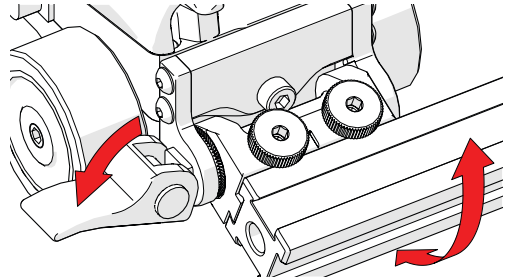

Fig. 41 - Pivot

The pivot nose is used as an attachment point for various frame bars.

To attach a frame bar, loosen both dovetail jaws, mount the frame bar and tighten knobs (*Fig. 40*).

The angle of the bar can be adjusted by loosening the side mounted lever, pivoting to the desired angle, and closing the lever again (*Fig. 41*).

4.1.8. Chain Mount

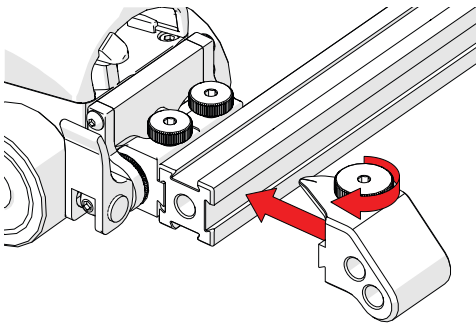

Fig. 42 - Chain mount

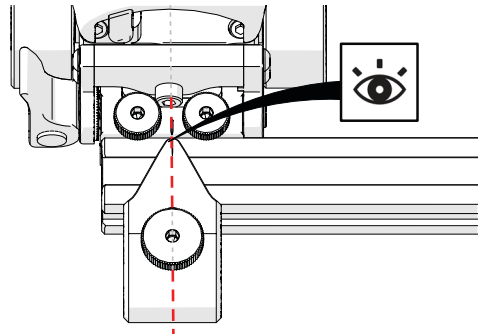

Fig. 43 - Chain mount alignment

The chain mount provides a connection point for links.

Secure to the frame bar by tightening the knob (*Fig. 42*). Centre the chain mount by lining up the marker with the centre point marker (*Fig. 43*) on the cart's front pivot.

4.1.9. Frame Bar

Frame bars (*Fig. 44*) are used to mount probe holders, probe positioning systems and other accessories (see *Frame Bars on page 52*).

Frame bars are available in a variety of lengths.

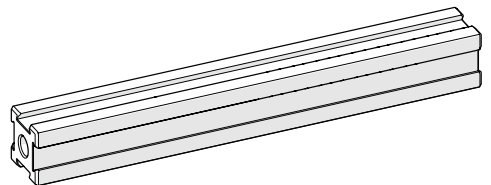

Fig. 44 - Frame bar

4.1.10. Pivot Buttons

Available in a variety of shapes and sizes fitting various wedge dimensions.

Use the supplied 3/8 in wrench (Fig. 2) to remove and install pivot buttons in desired hole location (Fig. 45).

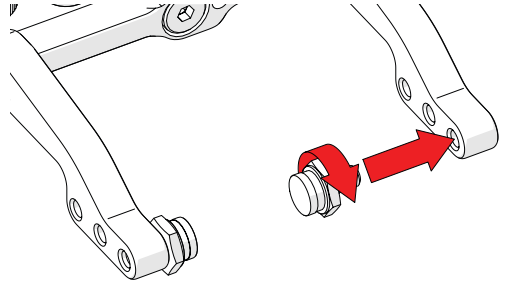

Fig. 45 - Pivot buttons

4.2. Chain Components

The chain components are used to fasten a scanning cart circumferentially around a pipe or tube.

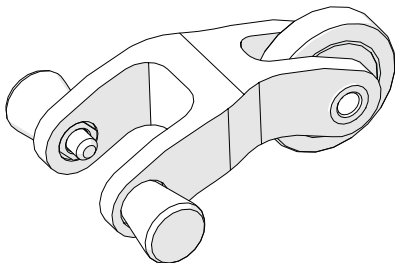

Fig. 46 - Short link

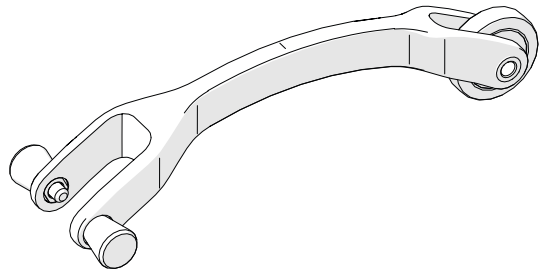

Fig. 47 - Long link

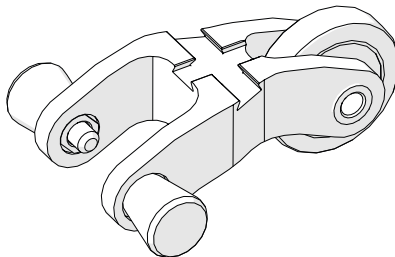

Fig. 48 - Dovetail link

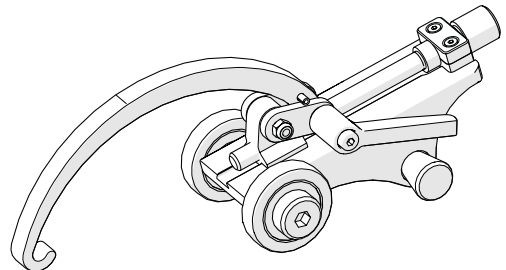

Fig. 49 - Buckle

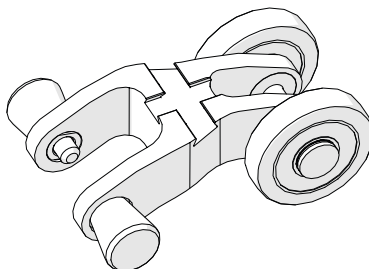

Fig. 50 - Catch link

4.2.1. Chain Connection

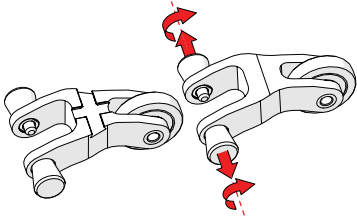

Fig. 51 - Pull out and twist pins

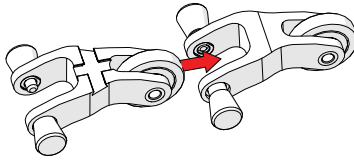

Fig. 52 - Align mounting holes

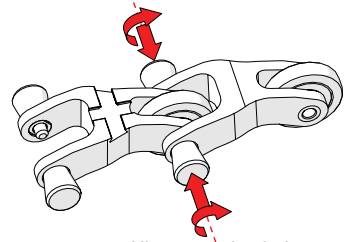

Fig. 53 - Align mounting holes

To connect chain components, see the following steps:

1. Pull the pins out from the wheels, twist a quarter turn latching the pins in a retracted state (Fig. 51).
2. Align the pins with the mounting holes of the component to be connected (Fig. 52).
3. Twist the pins until they unlatch and extend into the hole of the connected component (Fig. 53).

4.3. Stabilizer Wheel

The stabilizer wheel is used to balance the frame bar and to keep the frame bar parallel to the inspection surface.



WARNING! MAGNETIC MATERIAL. The stabilizer wheel uses a magnetic wheel. People with pacemakers or ICD's must stay at least 25 cm (10 in) away.

4.3.1. Installing a stabilizer wheel

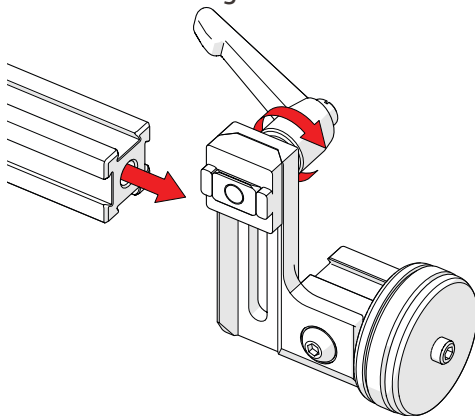

Fig. 54 - Attach frame bar

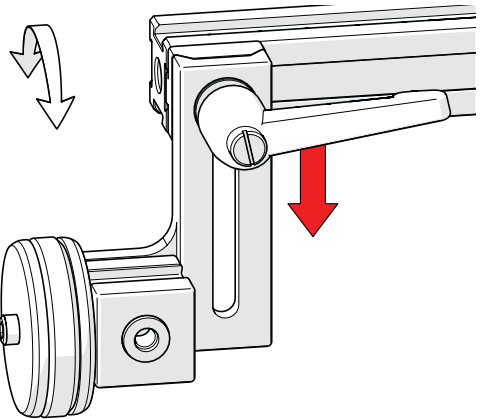

Fig. 55 - Position horizontally

To install the stabilizer wheel, ensure the dovetail nut is loose using the black ratchet lever (Fig. 54). Slide the dovetail nut onto the frame bar (Fig. 54).

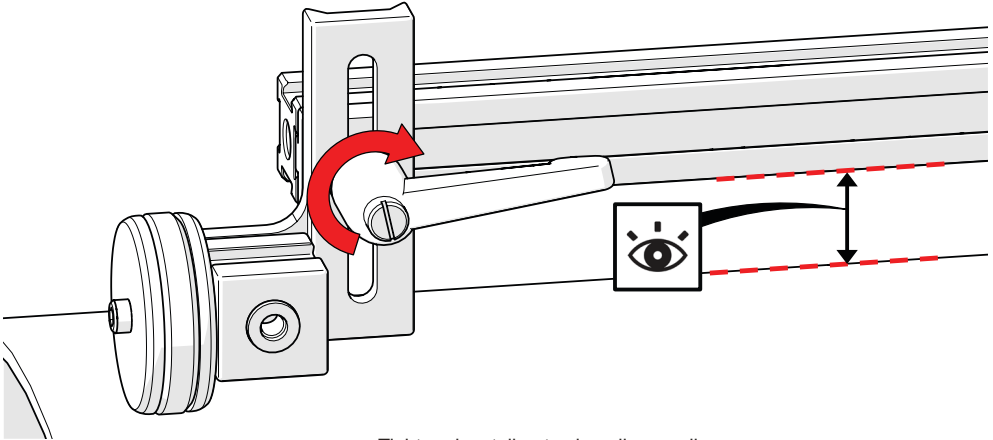

Fig. 56 - Tighten dovetail nuts along linear rail

Adjust the height of the stabilizer wheel's frame bar mount (Fig. 55) to ensure the frame bar is parallel with the inspection surface (Fig. 56).

Tighten using the black ratchet lever (Fig. 56).

TIP: The position of the ratchet handle can be manipulated by pulling the handle out and rotating.

4.3.2. Ratchet Lever

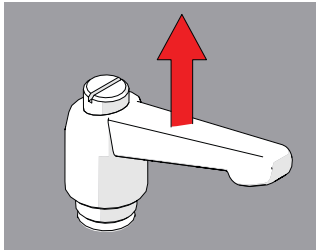

Fig. 57 - Pull ratchet handle

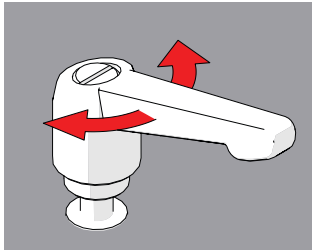

Fig. 58 - Rotate handle

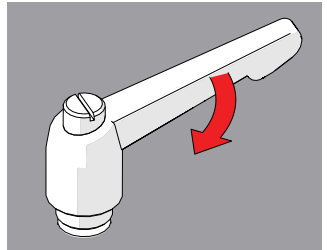

Fig. 59 - Tighten handle

The ratchet levers are used for various locking functions on the **ROTIX** system. Occasionally, movement of the lever locking position is required. The lever placement can be adjusted by following these steps:

1. Pull the ratchet lever away from the base of which it is connected (Fig. 57).
2. Continue to pull while rotating the lever in the appropriate direction (Fig. 58).
3. Release the lever and utilize the new tightening position.

4.4. Probe Positioning System (PPS)

The probe positioning system (PPS) uses a linear rail and leadscrew system to position two or four probes for weld inspection. Used to adjust probe to probe spacing as well as allow the operator to center probes over the weld without removing the scanner. To operate a probe positioning system (see *Using a Probe Positioning System (PPS) on page 10*)

4.4.1. Installing a Probe Positioning System

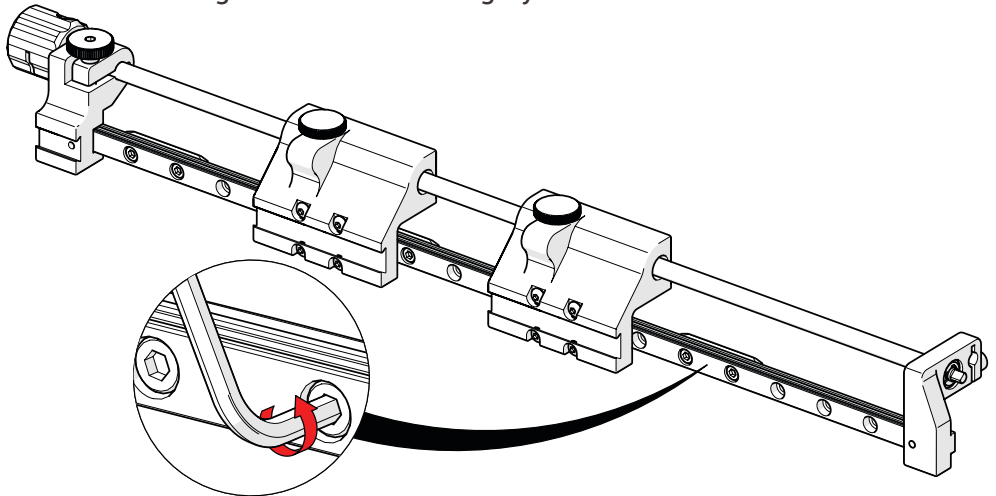

Fig. 60 - Slightly loosen all dovetail nuts

1. To install the PPS to a frame bar, ensure all the dovetail nuts are loose (*Fig. 60*) using a 2.5 mm hex wrench (*Fig. 5*).

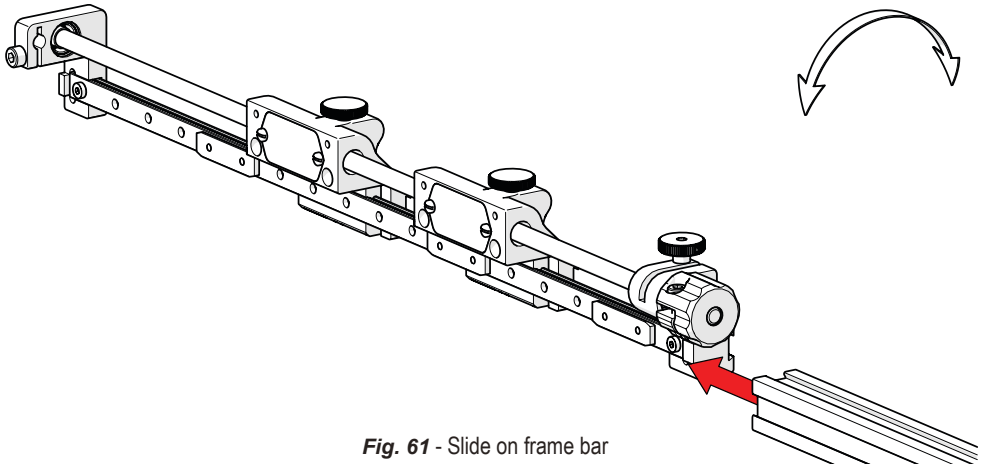

Fig. 61 - Slide on frame bar

2. Slide the assembly onto the frame bar (*Fig. 61*) and tighten both hexagonal screws in each dovetail nut (*Fig. 62*).

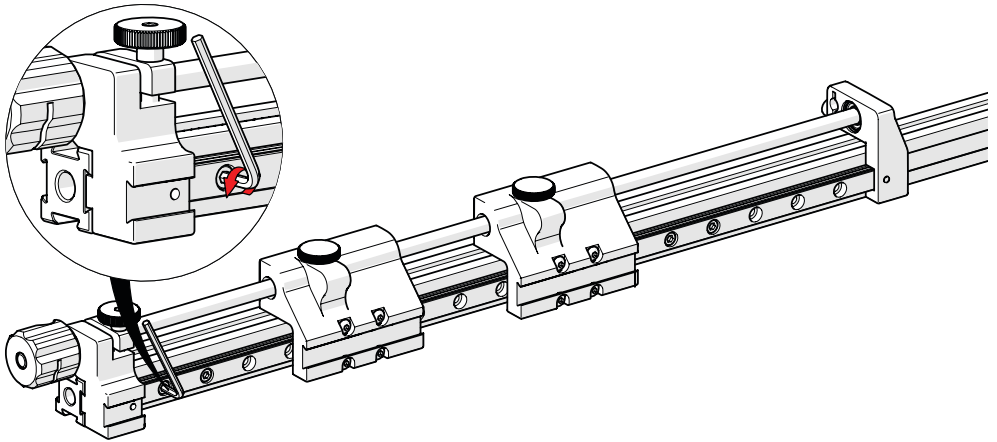

Fig. 62 - Tighten dovetail nuts along linear rail

TIP: In most applications, mounting the frame bar flush with the knob side of the PPS is recommended.

4.4.2. Four Probe Setup

It is possible to augment the probe positioning system to a four probe setup.

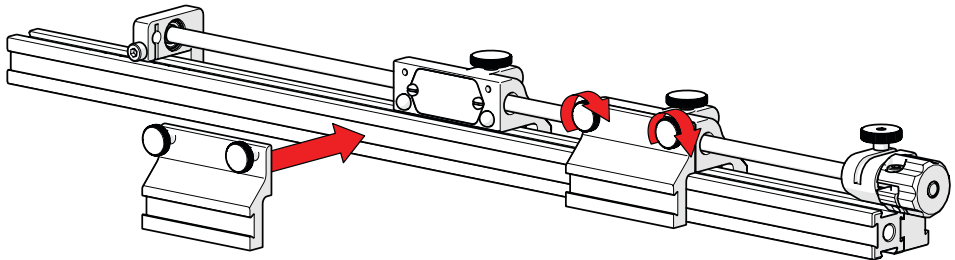

Fig. 63 - Position the probe holders and screw knobs tight

To attach the PPS slider backing plate, align the plate with the corresponding backing plate and tighten the 2 knobs (Fig. 63).

4.4.3. Index Encoding

The index encoder is used to provide positional feedback perpendicular to the scan direction of travel.

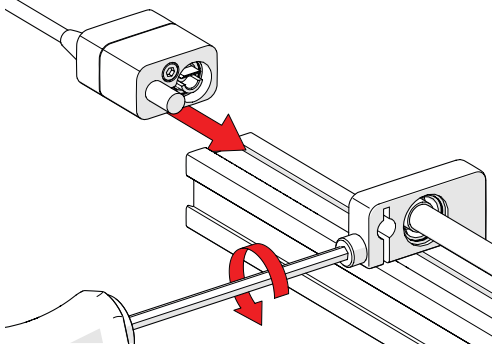

Fig. 64 - Loosen and slide post in place

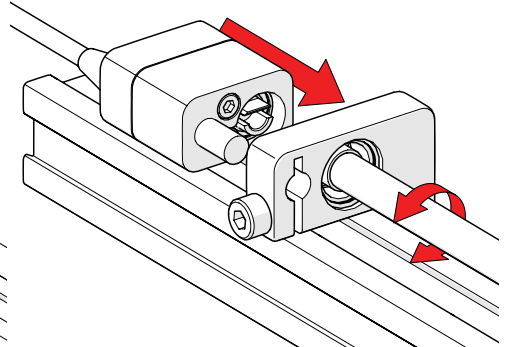

Fig. 65 - Align and mount post

1. To install the index encoder, loosen the clamp screw of the index encoder support bracket with the supplied 3 mm hex driver (*Fig. 64*).
2. Insert the encoder post in the index encoder support bracket while aligning the leadscrew shaft with the encoder socket (*Fig. 65*).

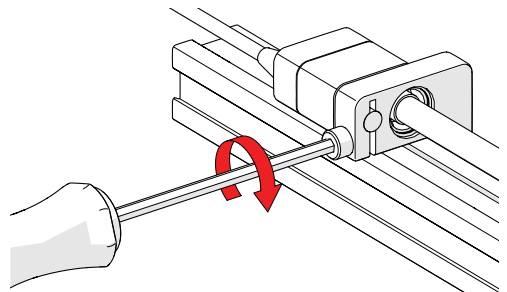

Fig. 66 - Tighten clamp screw

TIP: You can rotate the leadscrew by hand to assist in alignment of the encoder socket.

3. Lock the encoder in place by tightening the 3 mm clamp screw on the index encoder support bracket (*Fig. 66*).
4. Remove the cart handle (*Fig. 34*) from the cart body.
5. Plug the encoder connector into the auxiliary connector on the umbilical face of the cart.
6. Replace cart handle.

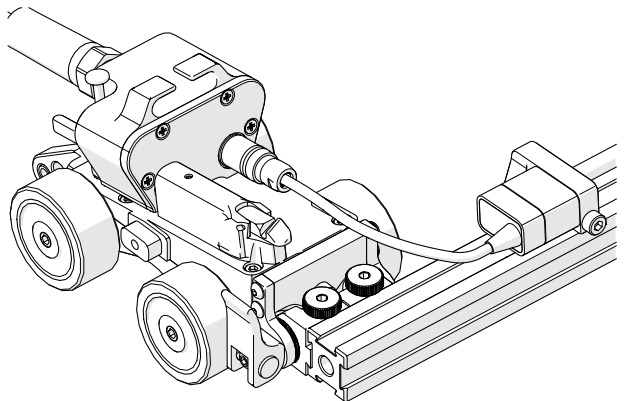
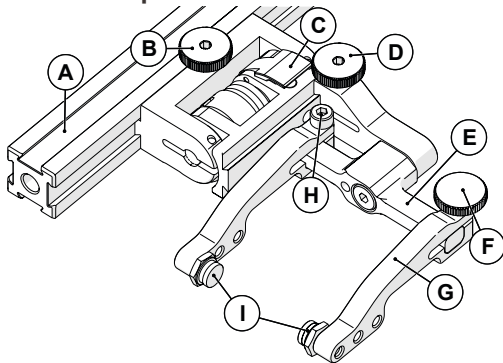

Fig. 67 - Connect encoder to umbilical

4.5. Slip Joint Probe Holder



- A** Frame Bar
- B** Probe Holder Adjustment Knob
- C** Latch
- D** Swing Arm Knob
- E** Yoke
- F** Probe Holder Arm Adjustment Knob
- G** Probe Holder Arm
- H** Arm Clamp Screw
- I** Pivot Buttons

Fig. 68 - Slip Joint Probe Holder

4.5.1. Probe Holder Setup

To mount a UT wedge in the probe holder, follow these steps:

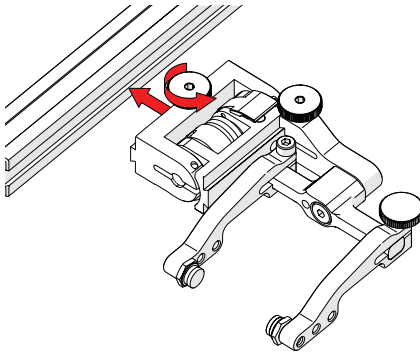

Fig. 69 - Attach to frame bar

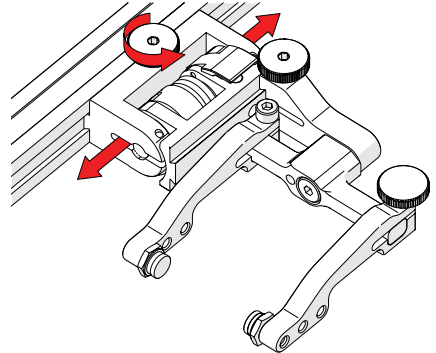

Fig. 70 - Adjust on frame bar

- 1.** Rotate the probe holder adjustment knob and attach probe holder to a frame bar (*Fig. 69*).
- 2.** Use the probe holder adjustment knob to position the probe holder along the frame bar (*Fig. 70*).

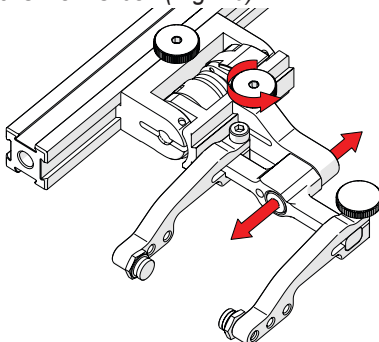

Fig. 71 - Adjust swing arm

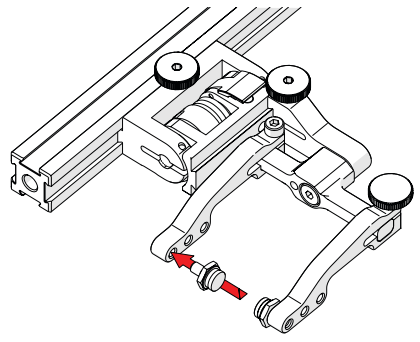

Fig. 72 - Place pivot buttons

3. Use swing arm knob to position the swing arm (Fig. 71).

TIP: The swing arm is typically used to adjust TOFD center to center distance relative to the phased array probes on a four probe configuration (Fig. 12).

4. Using the supplied 3/8 in wrench (Fig. 2), place the pivot buttons as required (Fig. 72).

TIP: If narrow scanning footprint is required, use pivot button holes closest to the yoke. Wedge pivoting may be impeded when closer to the yoke.

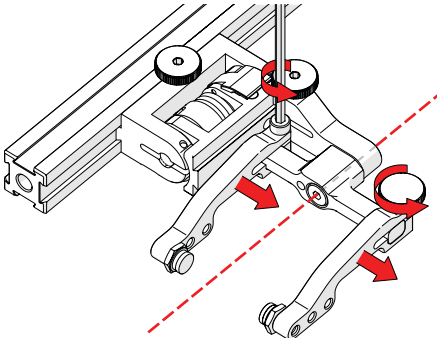

Fig. 73 - Adjust probe holder arms

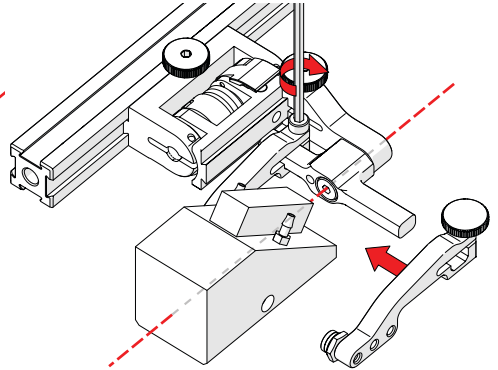

Fig. 74 - Place wedge

5. Loosen the probe holder arm adjustment knob (Fig. 73) and remove outer probe holder arm from yoke.
6. Adjust inner probe holder arm as required to best centre the probe on the yoke's pivot axis (Fig. 73).

TIP: The probe holder yoke can accommodate many different probe and wedge sizes of varying widths. It is best to centre the wedge with the yoke's pivot axis to reduce wedge tipping when scanning. Position the inner probe holder arm accordingly with the centre of the yoke (Fig. 73).

7. Position the wedge on the inner probe holder arm (Fig. 74).
8. Slide outer probe holder arm along the yoke pinching the wedge in place.
9. Tighten probe holder arm adjustment knob (Fig. 75).

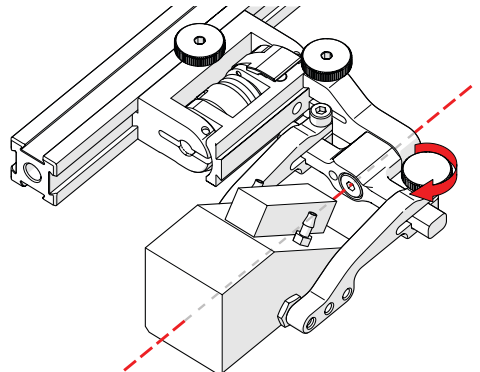

Fig. 75 - Pinch wedge with arm

4.5.2. Probe Holder Adjustment

To adjust the probe holder, follow these steps:

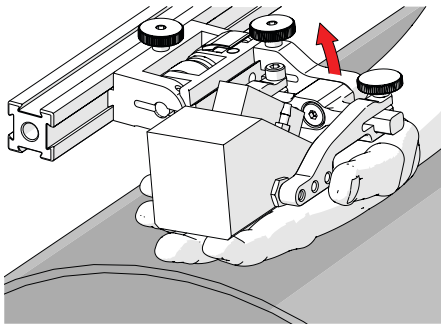

Fig. 76 - Lift to Latched position

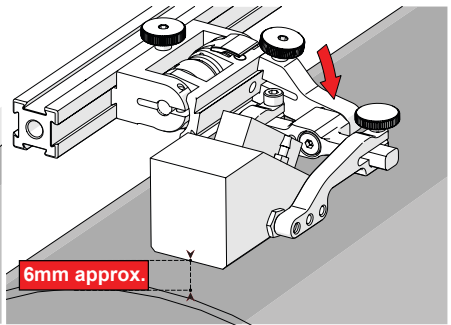

Fig. 77 - Lower to scanning surface

1. Ensure probe holder is in latched, upper position (Fig. 76). If the probe holder is already latched, it will only move within the slip joint adjustment range and have no spring tension.
2. Push the probe holder yoke down toward inspection surface until the wedge is approximately 6 mm ($\frac{1}{4}$ in) above the inspection surface (Fig. 77).

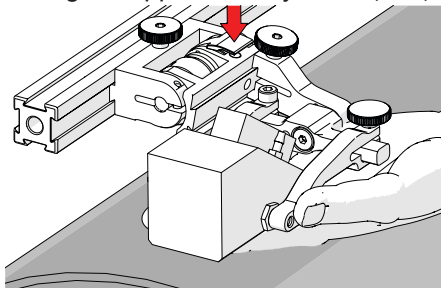

Fig. 78 - Lift and press latch button

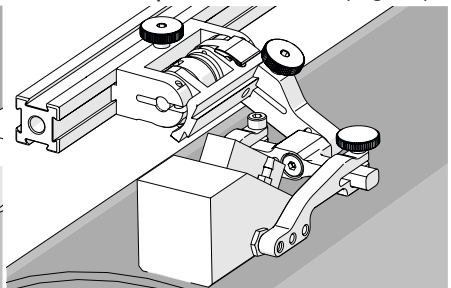

Fig. 79 - Spring loaded scan position

3. Lift probe slightly and press latch button (Fig. 78) to apply spring pressure to the wedge.
4. Gently lower probe holder and wedge to the scanning surface (Fig. 79).

4.5.3. Probe Holder Force Adjustment

It is possible to adjust the tension of the probe holder spring.

NOTE: To perform this operation the 2 mm hex wrench (Fig. 4) and 3 mm hex wrench (Fig. 6) is required.

| | | |
|---------------|------|------|
| Light | 1 kg | 2 lb |
| Medium | 2 kg | 4 lb |
| Heavy | 3 kg | 6 lb |

When configured correctly, these settings exert the indicated spring force on the Probe.

To adjust the probe holder's force, follow these steps:

NOTE: Do not perform this operation on scanning surface.

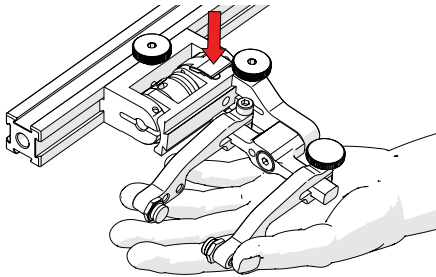

Fig. 80 - Lift slightly and press Latch

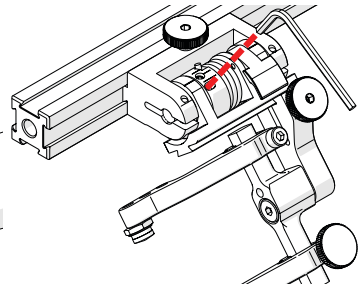

Fig. 81 - Unlatched position

1. Ensure the probe holder is in the upright latched position (Fig. 76).
2. Lift probe holder slightly and press the latch button (Fig. 80) to release the probe holder the full 45° degrees.
3. Insert the short arm of a 3 mm hex wrench into the 3 mm slot (Fig. 81).

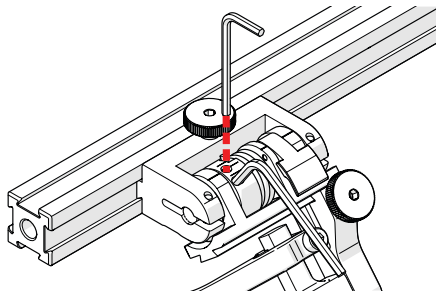

Fig. 82 - Insert hex wrenches

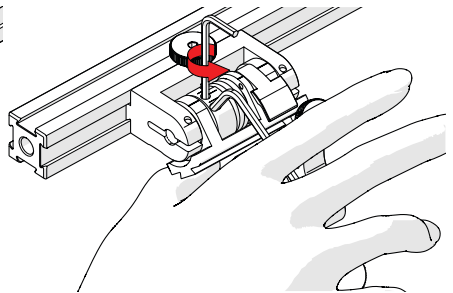

Fig. 83 - Press 3 mm hex wrench down

4. Place the 2 mm hex wrench into the force adjustment screw (Fig. 82).
5. Lightly press the long arm of the 3 mm hex wrench down. Using the 2 mm hex wrench, loosen the force adjustment screw but do not remove it (Fig. 83).
6. Gently apply pressure on the long leg of the 3 mm hex wrench until the force adjustment marker lines up with the desired spring tension. While keeping the markers in line, tighten the force adjustment screw (Fig. 84).

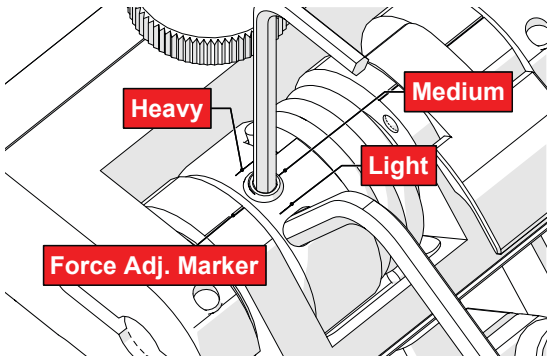

Fig. 84 - Choose desired tension

4.5.4. Slip Joint Probe Holder Left/Right Conversion

To reverse the probe holder, follow these steps:

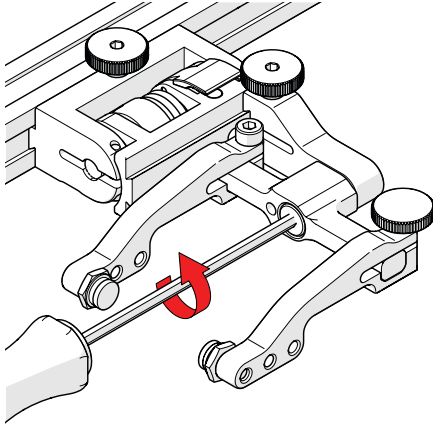

Fig. 85 - Unscrew yoke pivot screw

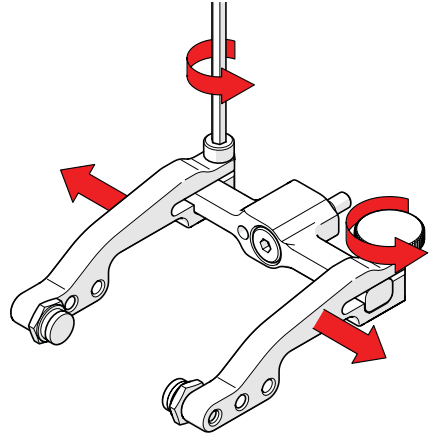

Fig. 86 - Remove arms

1. Unscrew the yoke from the swing arm (*Fig. 85*).
2. Loosen the probe holder arm adjustment knob and arm clamp screw. Slide the arms from the yoke (*Fig. 86*).

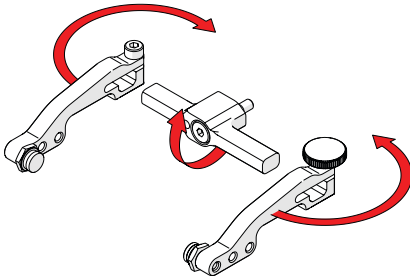

Fig. 87 - Flip yoke and reverse arms

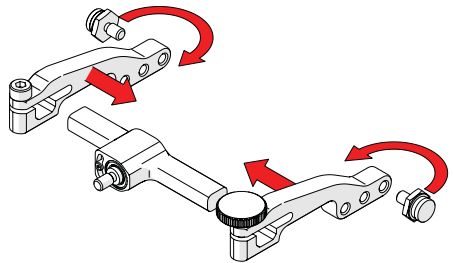

Fig. 88 - Attach arms and move buttons

3. Flip the yoke 180° and reverse the probe holder arms (*Fig. 87*).
4. Place the pivot buttons on the inside of the probe holder arms (*Fig. 88*) using a 3/8 in wrench (*Fig. 2*). Slide the arms onto the yoke and tighten the probe holder arm adjustment knob and the arm clamp screw.

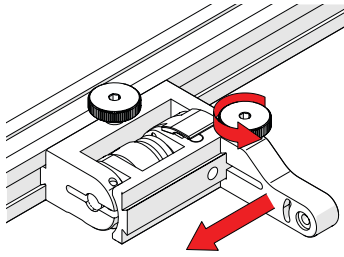

Fig. 89 - Position swing arm

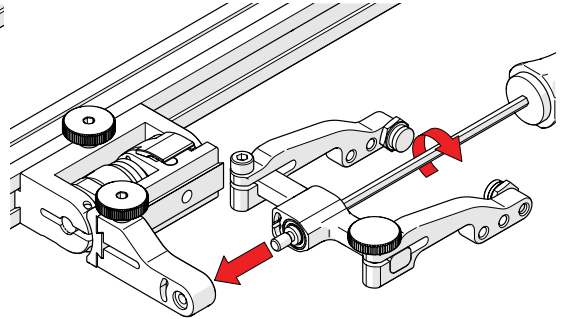

Fig. 90 - Install yoke to swing arm

- 5.** Loosen the swing arm knob and slide the swing arm to the opposite end of the probe holder bracket (*Fig. 89*) or preferred position. Tighten swing arm knob.
- 6.** Using the 3 mm hex driver, screw the yoke pivot screw into the opposite side of the probe holder swing arm (*Fig. 90*). Ensure the yoke is level to avoid issues with the plunger/set screw.

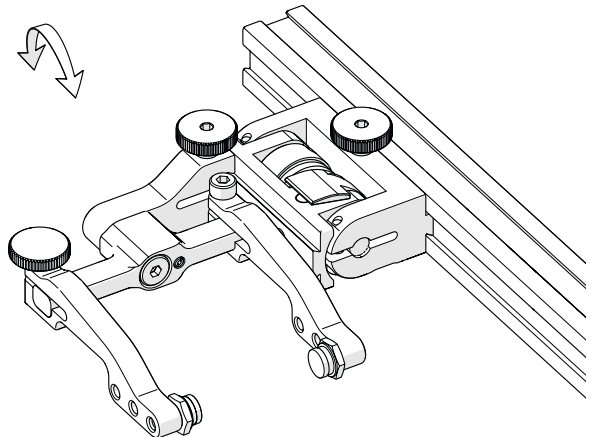

Fig. 91 - Reversed probe holder

4.6. Cable Management System

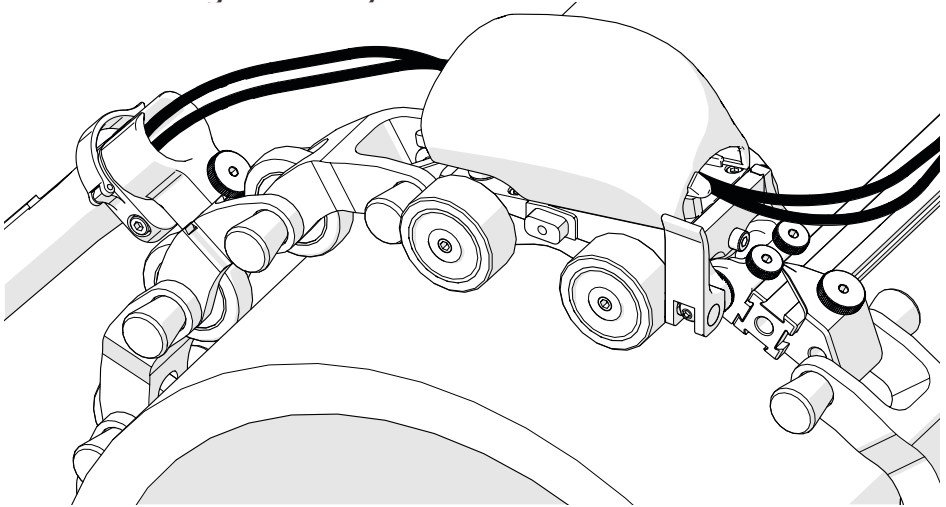

Fig. 92 - Cable management

TIP: When using the cable management, ensure the dovetail link is placed 2nd in the chain behind the cart body.

4.6.1. Cable Management Dovetail Mount

To attach the cable management, follow these steps:

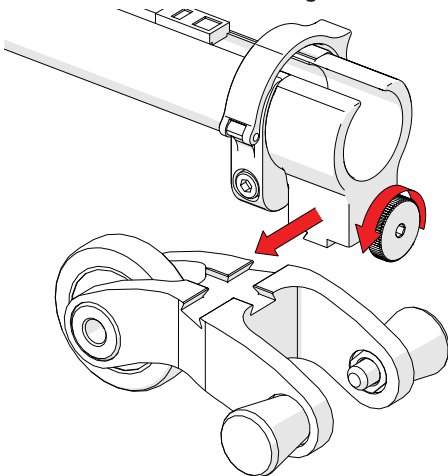

Fig. 93 - Loosen and slide on

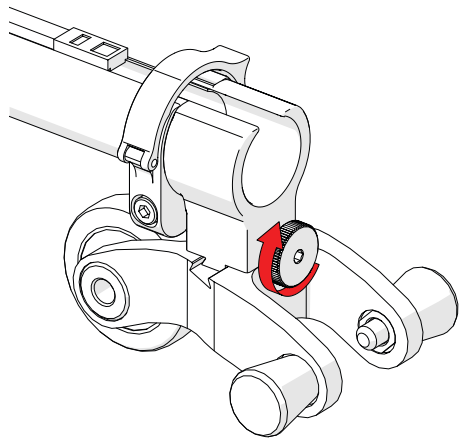

Fig. 94 - Tighten knob

- 1.** Loosen the knob on the cable management dovetail mount. Slide the mount onto the dovetail link (*Fig. 93*).
- 2.** Once centred on the dovetail link, tighten the cable management's dovetail mount knob (*Fig. 94*).

4.6.2. Cable Management Setup

Cable management is available in a variety of lengths and provides a means of bundling and protecting cables and hoses that run to a scanner.

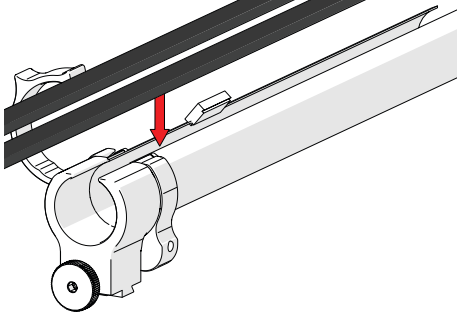

Fig. 95 - Insert cables and hoses

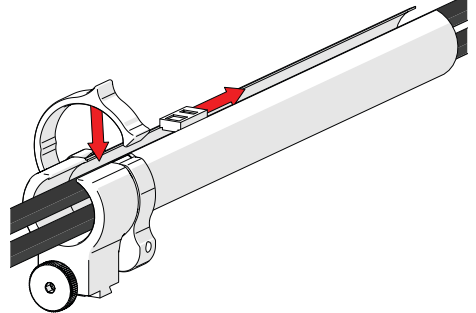

Fig. 96 - Zip up to close

1. Open the zipper of the cable management. Begin at the tube's dovetail mount and place the cabling in the tube (*Fig. 95*).
2. Follow the cable placement zipping the tube closed (*Fig. 96*).

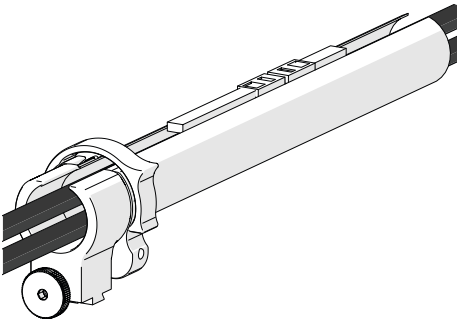

Fig. 97 - Zip opposite end

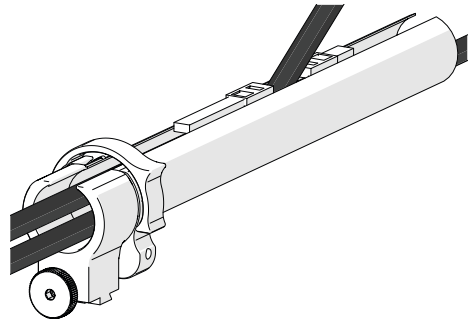

Fig. 98 - Flexibility

3. Once the cable is placed the entire length of tube, bring the zipper from the tubes opposite end, meeting at any point in the middle (*Fig. 97*).
4. When necessary, the two zippers may be opened to allow any cables to exit the tube anywhere between the ends (*Fig. 98*).

4.6.3. Clamp Setup

If the tube becomes disconnected from the cable management dovetail mount, follow these instructions to re-attach the tube and dovetail mount.

1. Loosen the clamp screw using the supplied 3 mm hex driver.
2. Slide the clamp around the tube first and then slide the tube around the outside of the cable management dovetail mount (Fig. 99). Align the zipper opening and the cable management dovetail mount opening.
3. Slide the clamp over the tube and cable management dovetail mount pinching the tube in between (Fig. 100).
4. Tighten the clamp screw (Fig. 101).

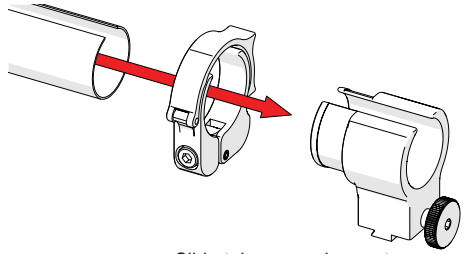

Fig. 99 - Slide tube around mount

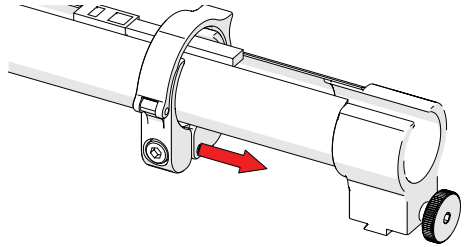

Fig. 100 - Slide clamp onto mount

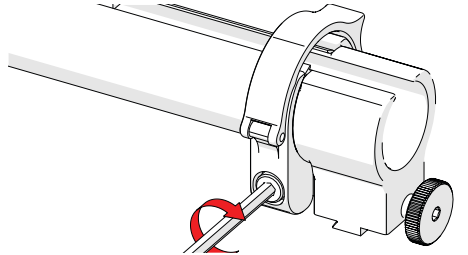

Fig. 101 - Tighten clamp screw

4.7. Reduced Width Scanning Kit

The encoded probe holding link houses the main encoder and provides a mounting base for probe holders.

To mount/adjust the frame bar, loosen the bar adjustment knobs, insert bar, slide to desired placement, then tighten bar adjustment knobs.

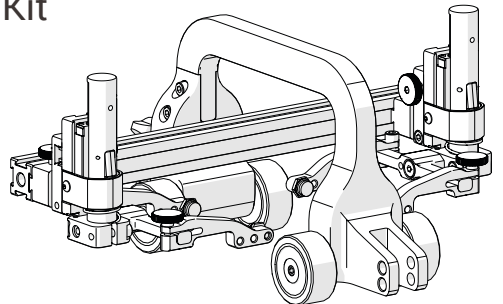

Fig. 102 - Reduced width scanning kit

4.8. Vertical Probe Holder

- A** Latch
- B** Probe Holder Adjustment Knob
- C** Vertical Adjustment Knob
- D** Pivot Buttons
- E** Probe Holder Arms
- F** Yoke
- G** Probe Holder Arm Adjustment Knob
- H** Transverse Adjustment Screw
- I** Frame Bar

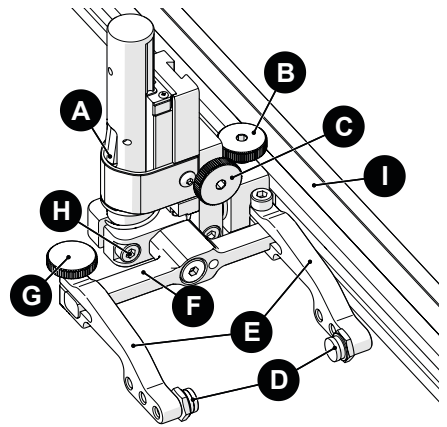

Fig. 103 - Vertical probe holder

4.8.1. Probe Holder Setup

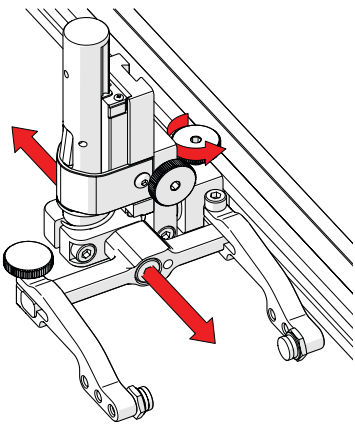

Fig. 104 - Adjust on frame bar

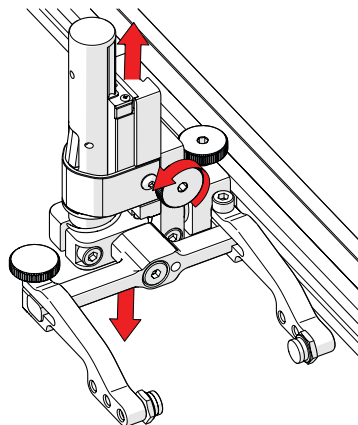

Fig. 105 - Vertical adjustment

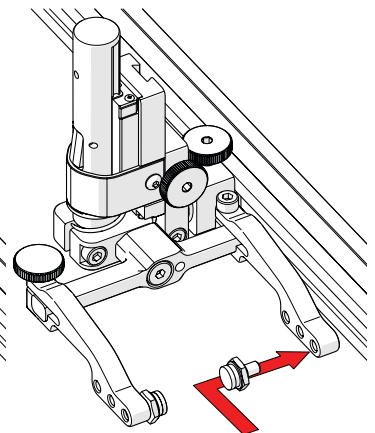

Fig. 106 - Place buttons

1. The probe holder adjustment knob allows the probe holder to be attached to a frame bar, as well as horizontal positioning on a frame bar (Fig. 104).
2. The vertical adjustment knob allows the vertical probe holder height adjustment (Fig. 105).
3. Position the pivot buttons where necessary (Fig. 106). When a narrow scanning footprint is required, use the pivot button holes closest to the yoke.

TIP: Probe pivoting may be impeded when closer to the yoke.

To mount a UT wedge in the probe holder, follow these steps

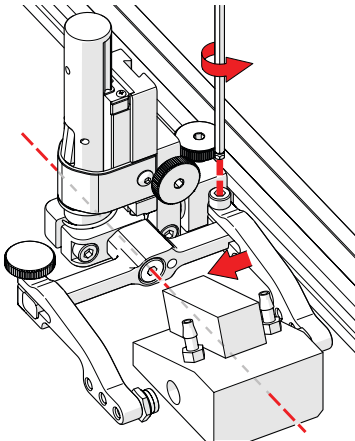

Fig. 107 - Adjust inner arm

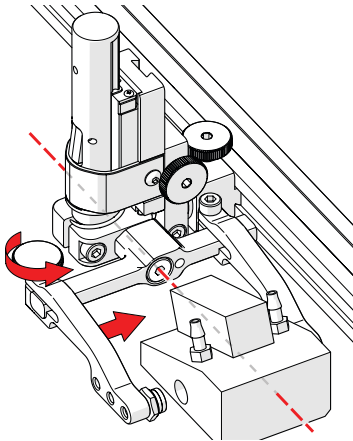

Fig. 108 - Adjust outer arm

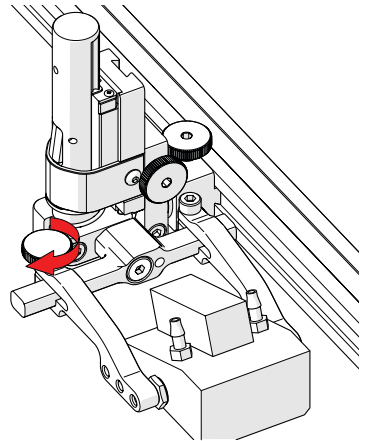

Fig. 109 - Tighten arm knob

4. Position the wedge on the inner probe holder arm.

TIP: The probe holder yoke can accommodate many different probe and wedge sizes of varying widths. It is best to centre the wedge with the yoke's pivot axis. This can reduce wedge tipping when scanning. Position the inner probe holder arm accordingly (Fig. 107) using the supplied 3 mm hex driver (Fig. 1).

5. Loosen the probe holder arm adjustment knob (Fig. 108) and slide the probe holder arm along the yoke pinching the wedge in place.
6. Tighten the probe holder arm adjustment knob (Fig. 109).

4.8.2. Probe Holder Vertical Adjustment

To adjust the probe holder vertically, follow these steps:

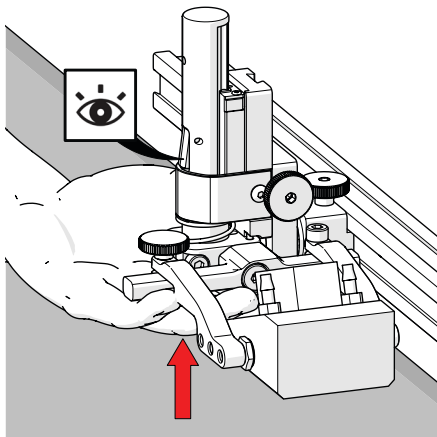

Fig. 110 - Latch probe holder

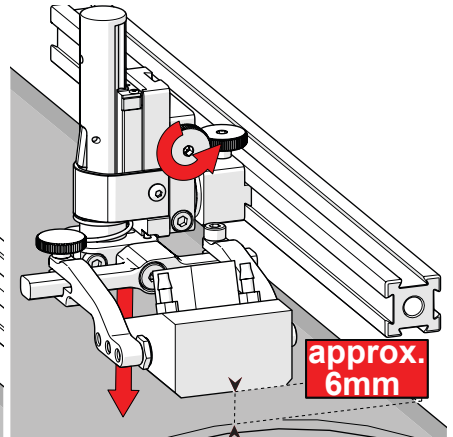

Fig. 111 - Lower toward scan surface

1. Ensure the probe holder is in the latched, upper position. Do this by lifting the probe holder till the latch is fully exposed (Fig. 110).
2. Loosen the vertical adjustment knob and slide the probe holder down until the wedge is approximately 6 mm ($\frac{1}{4}$ in) above inspection surface (Fig. 111).
3. Tighten the vertical adjustment knob.

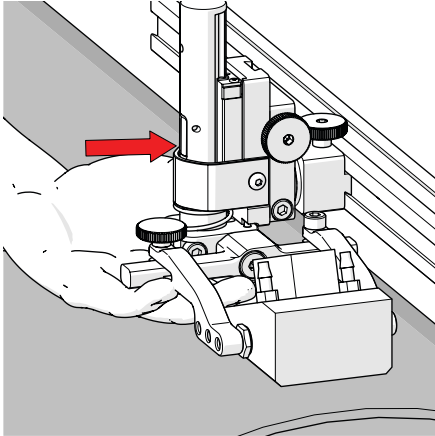

Fig. 112 - Press latch button

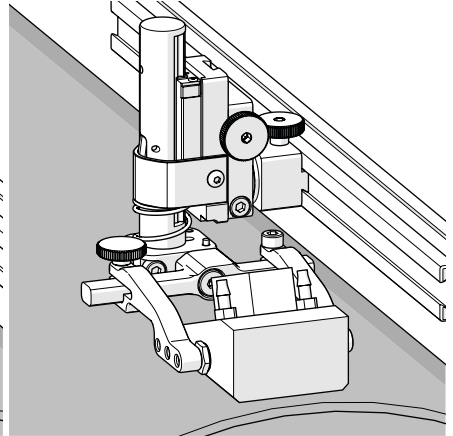

Fig. 113 - Lower toward scan surface

4. Lift the yoke slightly and press the latch button (Fig. 112), then slowly lower towards scanning surface to apply spring pressure to the wedge (Fig. 113).

TIP: If less spring force is desired, refer to step 2 and place the wedge approximately 20 mm ($\frac{3}{4}$ in) above inspection surface.

4.8.3. Probe Holder Transverse Adjustment

To adjust the probe holder's transverse angle, follow these steps:

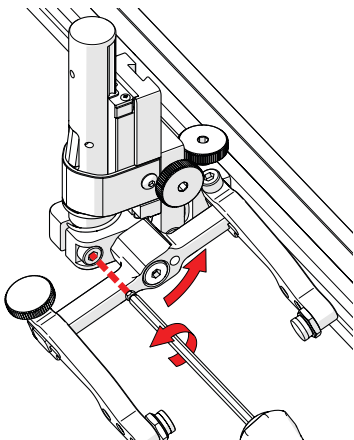

Fig. 114 - Loosen 3 mm screw

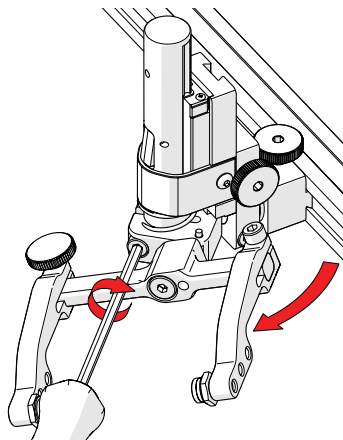

Fig. 115 - Rotate and tighten

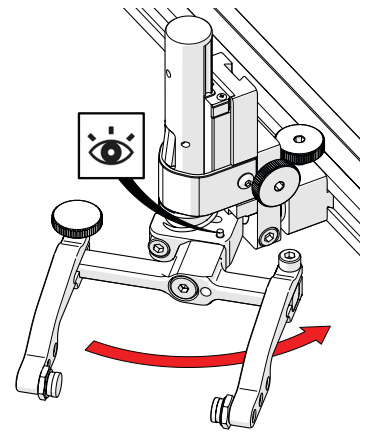

Fig. 116 - Stop post locates 90°

1. Ensure the probe holder is in latched, upper position (*Fig. 110*).
2. Using the supplied 3 mm hex driver loosen the transverse adjustment screw (*Fig. 114*) and rotate the yoke about the vertical shaft achieving the desired angle.
3. Tighten the transverse adjustment screw (*Fig. 115*).

To return the transverse adjustment to neutral (90°). The probe holder must be in the latched, upper position (*Fig. 110*). Rotate the yoke until the stop post contacts the base of the probe holder (*Fig. 116*). Then tighten the transverse adjustment screw.

4.8.4. Probe Holder Longitudinal Adjustment

To adjust the probe holder's vertical angle for longitudinal scanning, follow these steps:

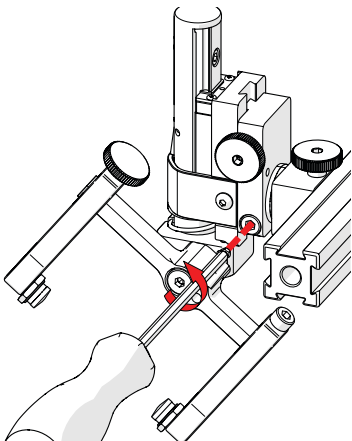

Fig. 117 - Loosen 3 mm screw

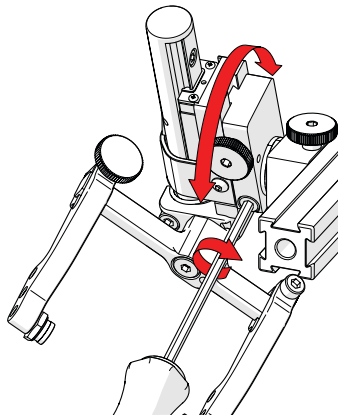

Fig. 118 - Rotate to position

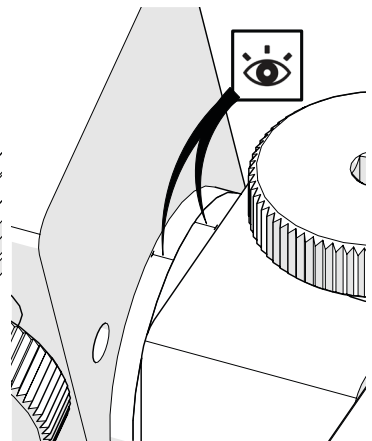

Fig. 119 - Line up markers

1. Ensure the probe holder is in latched, upper position (*Fig. 110*).
2. Using the supplied 3 mm hex driver (*Fig. 1*), loosen the longitudinal adjustment screw (*Fig. 117*).
3. Rotate the main body of the probe holder until it is at the desired angle.
4. Tighten the longitudinal adjustment screw (*Fig. 118*).

To return the longitudinal adjustment to neutral (90°). Line up the longitudinal adjustment indicator markers (*Fig. 119*).

4.8.5. Probe Holder Left/Right Conversion

To reverse the probe holder, follow these steps:

NOTE: To perform this operation the 1.5 mm hex wrench (Fig. 3) is required.

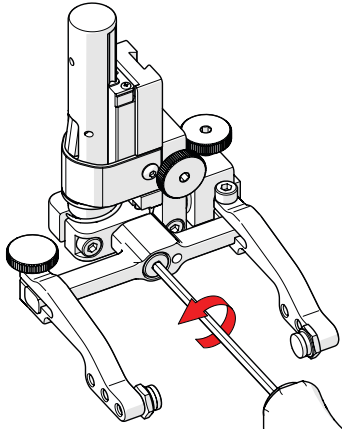

Fig. 120 - Unscrew yoke pivot screw

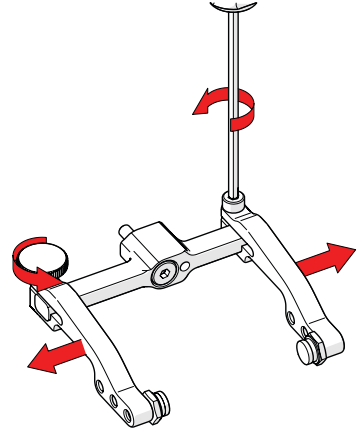

Fig. 121 - Remove probe holder arms

1. Ensure the probe holder is in latched, upper position (Fig. 110).
2. Using the supplied 3 mm hex driver (Fig. 1), unscrew the yoke pivot screw and remove yoke (Fig. 120).
3. Loosen the probe holder arm adjustment knob and the arm clamp screw. Slide the probe holder arms off the yoke (Fig. 121).

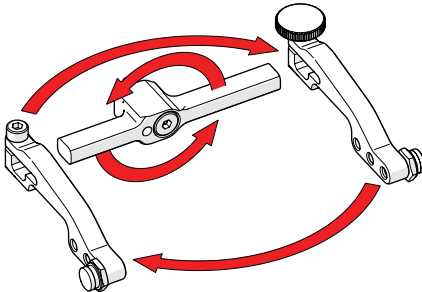

Fig. 122 - Flip yoke and reverse arms

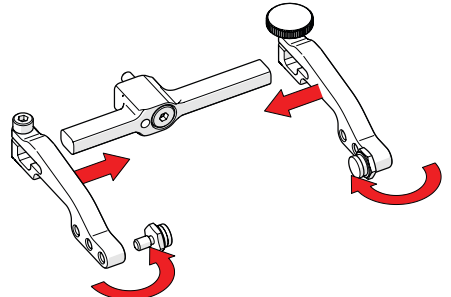

Fig. 123 - Attach arms & move buttons

4. Flip the yoke 180° and reverse the probe holder arms (Fig. 122).
5. Place the pivot buttons on the inside of the probe holder arms (Fig. 123) using a 3/8 in wrench (Fig. 2).

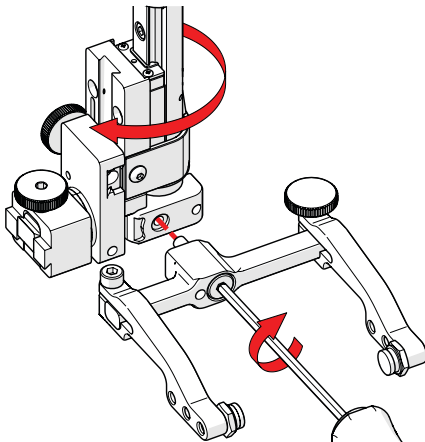

Fig. 124 - Screw yoke to opposite side

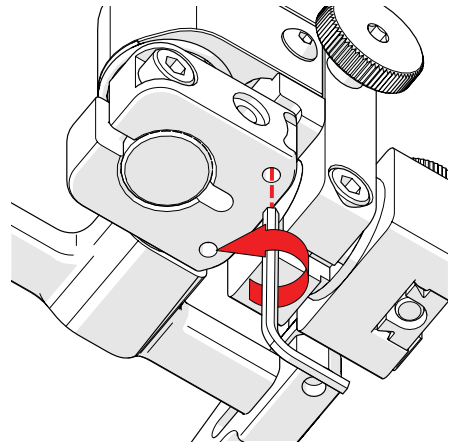

Fig. 125 - Lower 90° stop post

- 6.** Mount the yoke to the opposite side of the base using the supplied 3 mm hex driver (*Fig. 124*).

TIP: Keep the yoke level with the base as to ensure no conflicts with the plunger/set screw attached to the yoke.

- 7.** Locate the recessed M3 screw (*stop post*) on the bottom of the probe holder. Unscrew the stop post using a 1.5 mm hex wrench until it has cleared all obstructions. Do not remove stop post (*Fig. 125*).

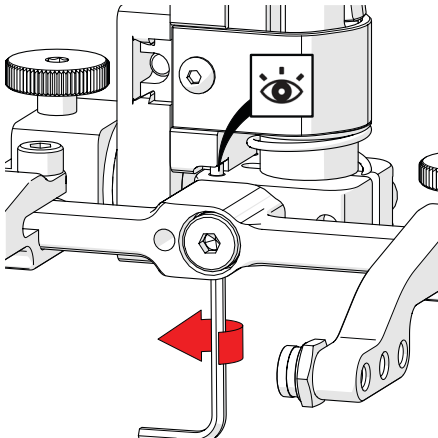

Fig. 126 - Raise opposite 90° stop post

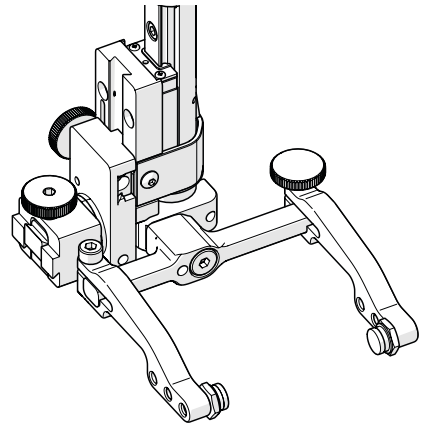

Fig. 127 - Reversed probe holder

- 8.** Raise the stop post on the opposite side until the side of the post clearly contacts the 90° stop point on the probe holder's base (*Fig. 126*).

4.9. Magnetic Wheel Kit

When the use of a chain scanner is not appropriate, the magnetic wheel kit (*Fig. 128*) can be used to replace the urethane wheels on a **ROTIX** scanner body. Two sets of the magnetic wheel kits can also be used on the cart body to double the magnetic force.

To install or remove wheels (*see Wheels on page 16*).

NOTE: Do not use the magnetic wheels in conjunction with a chain assembly.

NOTE: Magnetic wheels may lose their magnetic properties if heated above 175° F (80° C).

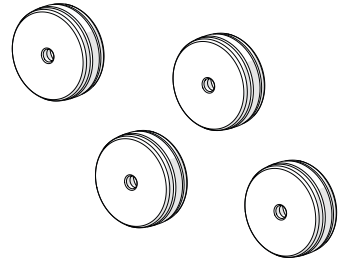

Fig. 128 - Magnetic wheel kit



WARNING! MAGNETIC MATERIAL. The magnetic wheel kit produce a magnetic field which may cause failure or permanent damage to items such as watches, memory devices, CRT monitors, medical devices or other electronics. People with pacemakers or ICD's must stay at least 25 cm (10 in) away.

4.10. Single PPS

Similar to the standard probe positioning system. The single PPS (*Fig. 129*) is commonly used for corrosion mapping. Use an additional backing plate to allow for two probe scanning. To instal and setup (*see Probe Positioning System (PPS) on page 21*).

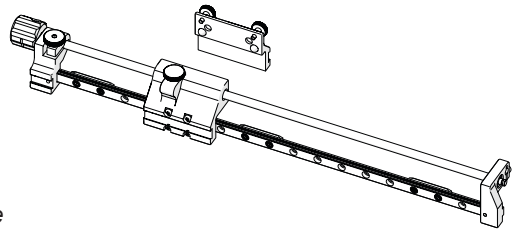

Fig. 129 - Single probe positioning system

4.11. Slider Probe Positioning System

The slider probe positioning system uses a slide and leadscrew system to position one or two probes for weld inspection. This system can be used to set the probe center spacing and also allows the operator to center the two probes over the weld without removing the scanner. To operate a slider PPS (see *Using a Slider Probe Positioning System (Slider PPS)* on page 13)

4.11.1. Slider PPS Assembly

To assemble a slider probe positioning system, follow these steps:

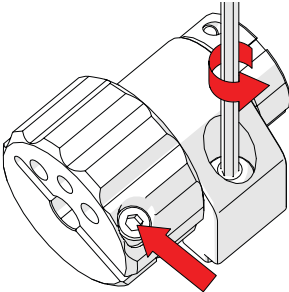

Fig. 130 - Loosen screws

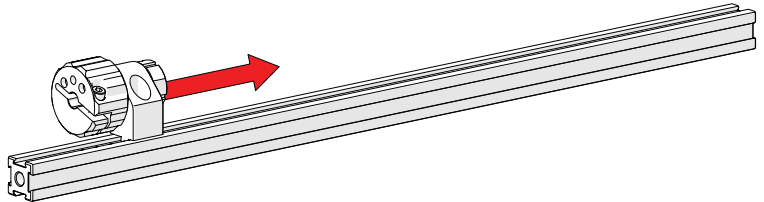

Fig. 131 - Slide main knob to middle of frame bar

1. Ensure the lock screw and the hexagonal screw in the main knob are loose (*Fig. 130*).
2. Slide the main knob to the middle of the frame bar (*Fig. 131*).

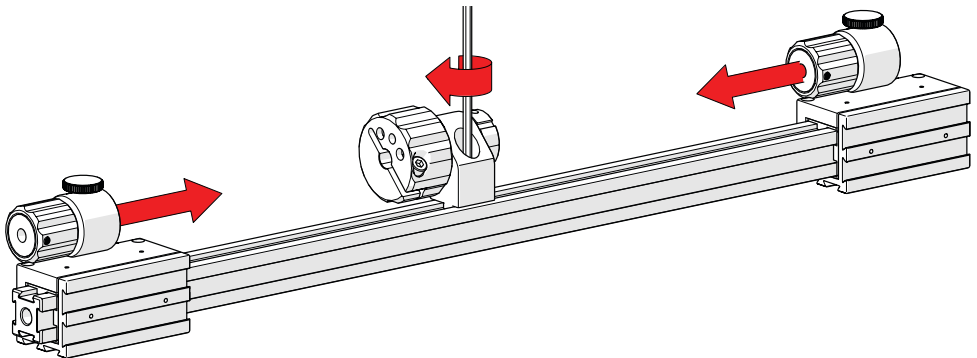

Fig. 132 - Attach slide assemblies and tighten lock screw

3. Tighten the lock screw on the main knob bracket (*Fig. 132*). Ease the two sliders onto either end of the frame bar and push the sliders to the desired position on the frame bar (*Fig. 132*). The slider's friction fit require an appropriate level of force to position the sliders.

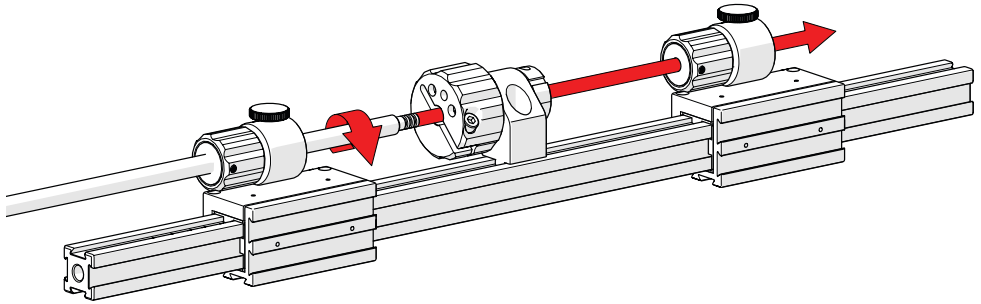

Fig. 133 - Screw leadscrew into place

4. Screw the leadscrew into the first slider, then the main knob and finally the 2nd slider assembly (*Fig. 133*).

NOTE: The leadscrew's encoder end must be positioned on the same side as the cart.

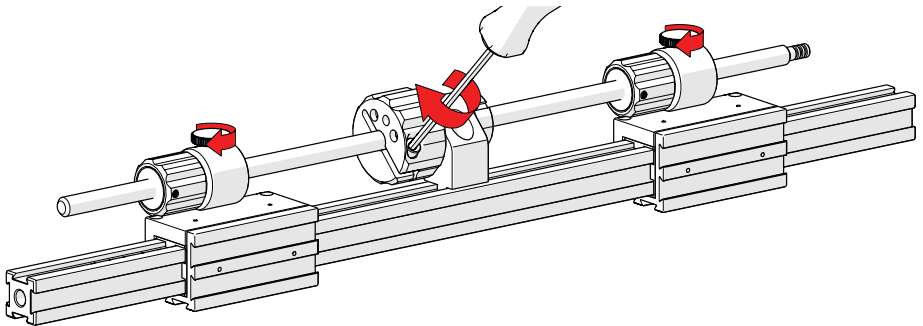

Fig. 134 - Tighten hexagonal screw

5. Tighten the main knob's hexagonal screw (*Fig. 134*).

4.11.2. Slider Index Encoding

The slider index encoder is used to provide positional feedback perpendicular to the scan direction of travel. Follow these steps for installation:

1. Ensure the encoder's lock screw is loose.

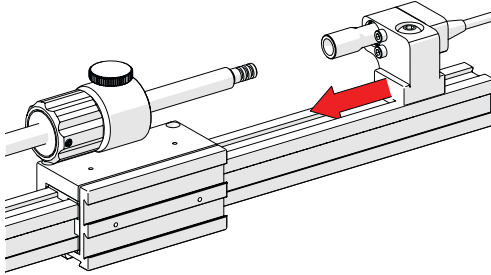

Fig. 135 - Loosen and slide post in place

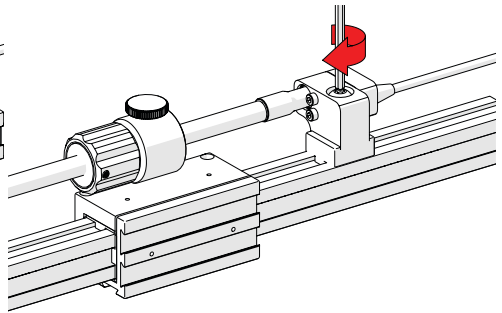

Fig. 136 - Align and mount post

2. Slide the encoder's dovetail nut onto the frame bar (*Fig. 135*), continue sliding the encoder towards the leadscrew until the leadscrew and the encoder's coupling are attached (*Fig. 136*).
3. Tighten the encoder's lock screw (*Fig. 136*).

TIP: Leave space for the pivot nose and chain mount when placing the encoder on the frame bar. If necessary, repeat the slider PPS installation (see *Slider PPS Assembly* on page 40) sequence and position the system with space for the chain mount.

4.12. Crank Handle

Used in conjunction with a single probe with slider PPS setup (*Fig. 13*). The crank handle provides faster probe positioning and greater ease of use. To install the crank handle follow these steps:

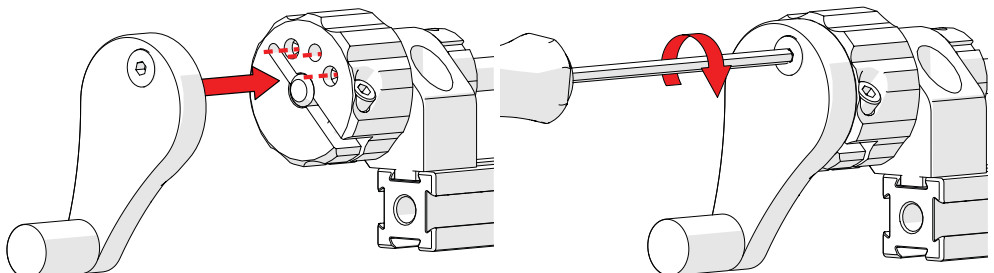

Fig. 137 - Align posts

Fig. 138 - Tighten screw

1. Align the dowels of the crank handle with the holes of the main knob (*Fig. 137*).
2. Using the supplied 3 mm hex driver (*Fig. 1*), tighten the hexagonal screw (*Fig. 138*).

5.1. Troubleshooting

| Problem | Possible Cause | Solution |
|---------------------------------------|--|---|
| 1. Chain is too loose/tight | Incorrect number or combination of links for proper scanner configuration. | Refer to the ROTIX setup chart (see <i>Chain Configuration Setup Chart on page 3</i>) for required number of links for the diameter of pipe/tube that is to be scanned. Ensure the correct outer diameter measurement of the pipe/tube. Reset the scanner with the correct number of links. |
| | Buckle is incorrectly setup | Adjust tightness of buckle |
| 2. Insufficient probe contact. | Scanner not set properly. | Reconfigure the scanner as per instructions (see <i>Probe Holder Adjustment on page 26</i>) |

5.2. Technical Support

For technical support, contact Jireh Industries (see *Jireh Industries Ltd. on page i*)

5.3. Disposal

WEEE Directive

In accordance with European Directive on Waste Electrical and Electronic Equipment (WEEE), this symbol indicated that the product must not be disposed of as unsorted municipal waste, but should be collected separately. Refer to Jireh Industries for return and/or collection systems available in your country.



SPARE PARTS

To order accessories or replacement parts for your **ROTIX** system.
(contact Jireh Industries Ltd. on page i)

NOTE: These drawings are for parts order. This is not a list of kit contents.

6.1. Rotix Cart

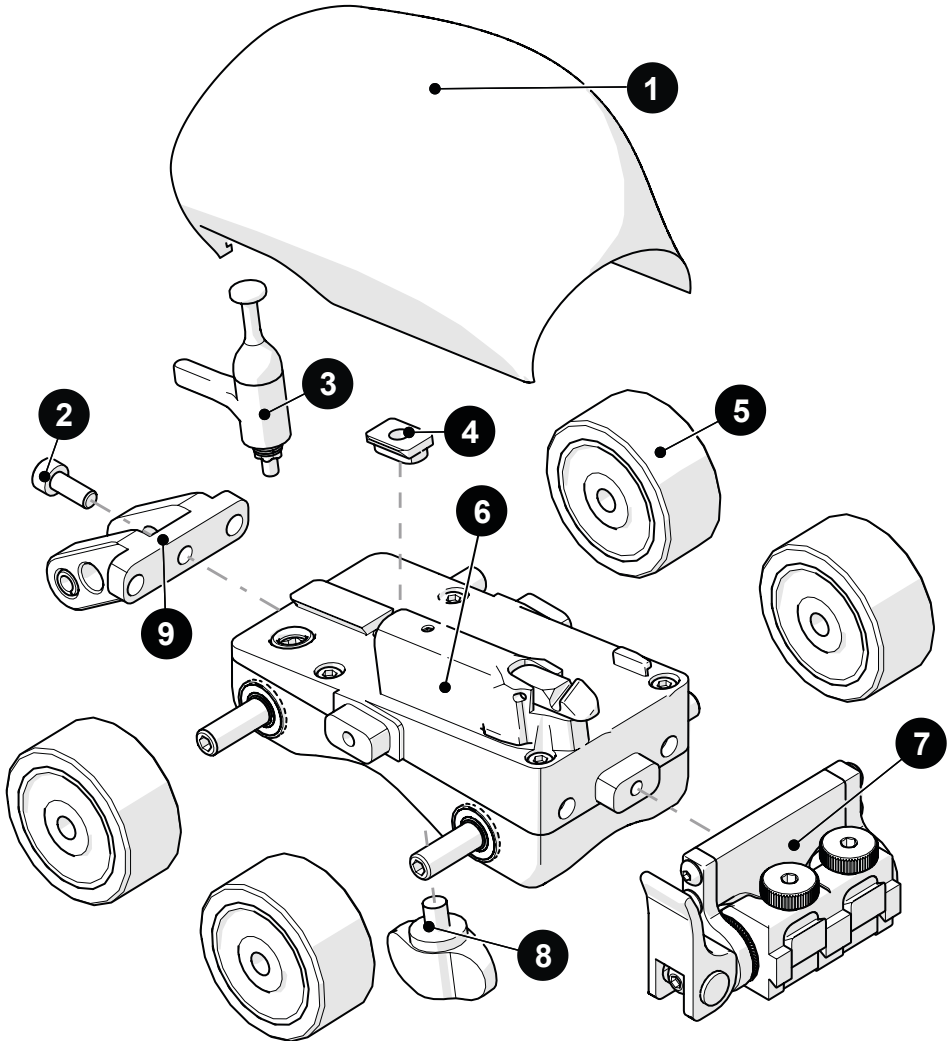
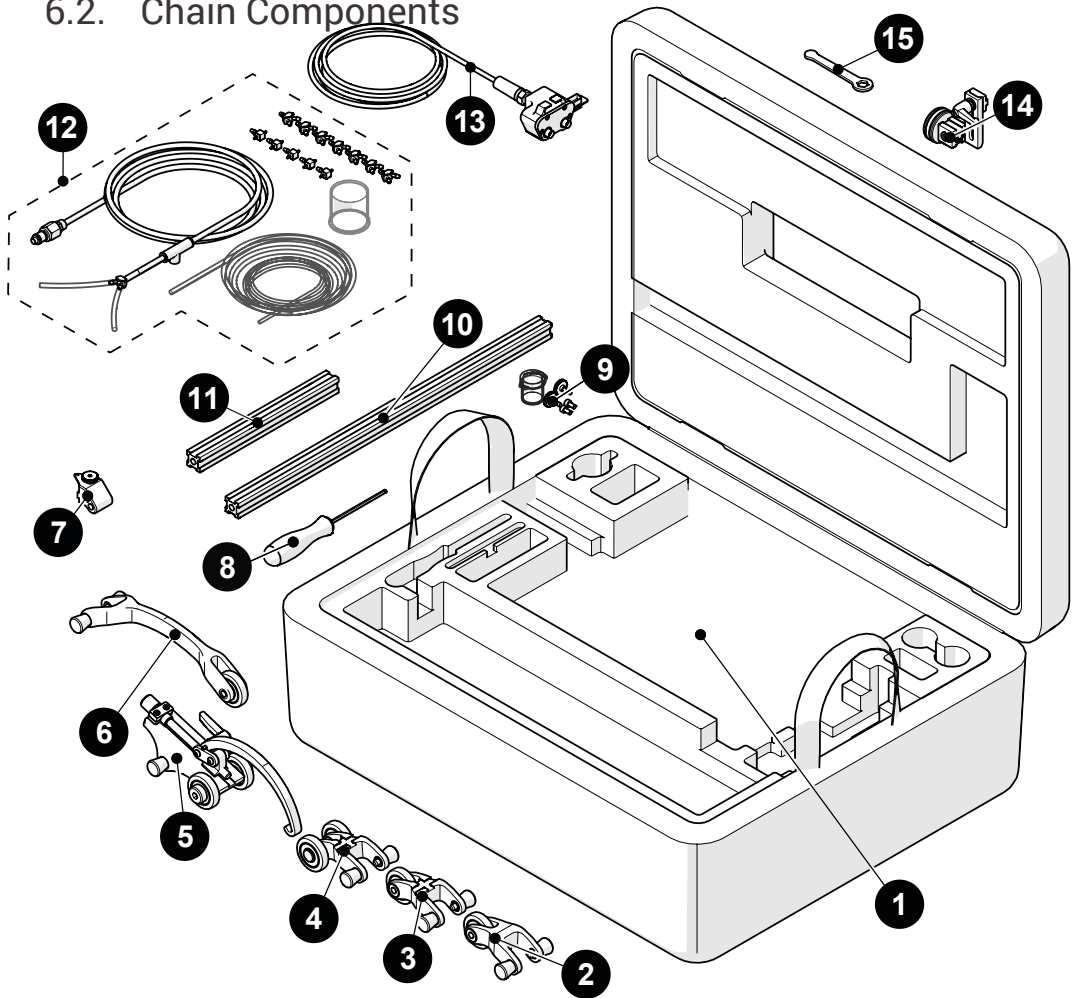

Fig. 139 - Cart parts

| BOM ID | Part # | Description |
|---------------|---------------|--------------------------------------|
| 1 | BT0150 | Handle |
| 2 | MD050-010 | SHCS, M4x0.7 X 10 mm, SST |
| 3 | BTS046 | Brake Handle |
| 4 | BT0014 | Dove Tail Nut |
| 5 | CES012 | Urethane Wheel |
| 6 | BTS045 | Base Cart |
| 7 | BTS040 | Microbe/Rotix Pivot Nose |
| 8 | BT0069 | Mini Wing Knob, M5 x 0.8 x 6 mm, SST |
| 9 | CES013 | Tail |

Fig. 140 - Cart parts (continued)

6.2. Chain Components



| BOM ID | Part # | Description | BOM ID | Part # | Description |
|--------|--------|--------------------------|--------|-------------|---|
| 1 | CEA002 | Rotix Case | 9 | PHG014 | 2 Probe Spare Parts Kit |
| 2 | CES002 | Short Link | 10 | BG0038-45 | Frame Bar, 45 cm |
| 3 | CES024 | Short Link with Dovetail | 11 | BG0038-20 | Frame Bar, 20 cm |
| 4 | CES003 | Catch Link (Red) | 12 | CMG007 | Irrigation Kit |
| 5 | CES005 | Buckle | 13 | UMA012-X-05 | Umbilical Housing (see Encoder Connector Type) |
| 6 | CES009 | Long Link | 14 | BTS049 | Stabilizer Wheel |
| 7 | CES028 | Chain Mount | 15 | EA470 | 3/8 in Wrench |
| 8 | EA414 | 3 mm Hex Driver | | | |

Fig. 141 - Rotix parts

6.2.1. Encoder Connector Type

| Connector Type | Company/Instrument | Connector Type | Company/Instrument |
|----------------|---|----------------|---|
| B | Olympus - OmniScan MX / Zetec - ZIRCON, TOPAZ | G | Sonotron - Isonic |
| C | Olympus - Focus LT / Zetec Z-Scan | M | GE - USM Vision |
| D | Olympus - OmniScan MX2, OmniScan SX | U | Sonatest - VEO, PRISMA |
| F | TD - Focus Scan, Handy Scan, Pocket Scan | V | Pragma PAUT 16/128, PragmaLite / Pragma UT400 |

Fig. 142 - Encoder connector type

NOTE: Additional encoder connector styles available. (contact Jireh Industries Ltd. on page i)

6.3. Probe Positioning

6.3.1. Probe Positioning System (PPS)

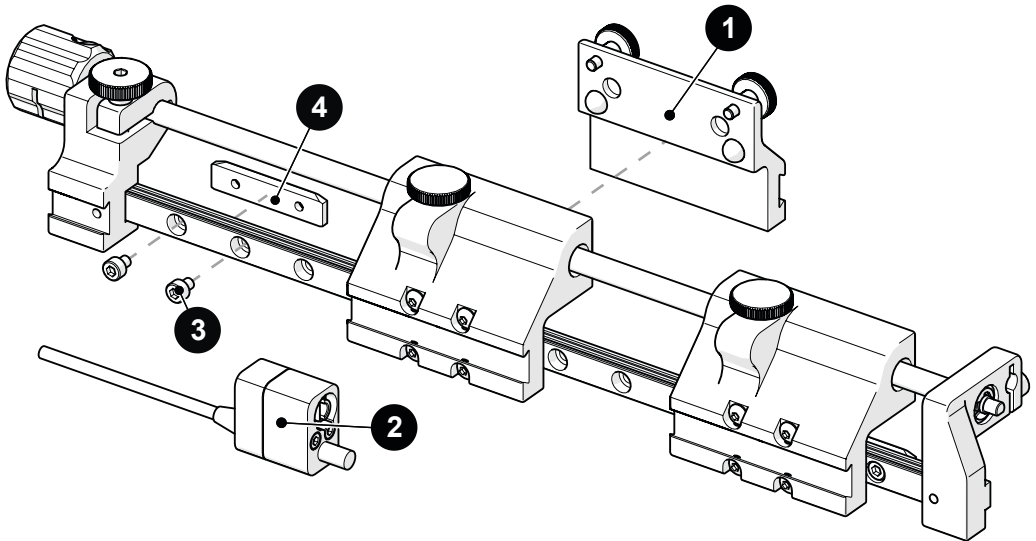

| BOM ID | Part # | Description |
|--------|--------------|--------------------------|
| 1 | DKS003 | Backing Plate |
| 2 | DKS009-S-0.3 | Index Encoder |
| 3 | MD049-004 | SHCS, M3x0.5 X 4 mm, SST |
| 4 | DK0020 | Dovetail Nut |

Fig. 143 - Probe positioning system parts

NOTE: Additional PPS lengths available. (contact Jireh Industries Ltd. on page i)

NOTE: Additional leadscrew lengths available. (contact Jireh Industries Ltd. on page i)

6.3.2. Slider Probe Positioning System (Slider PPS)

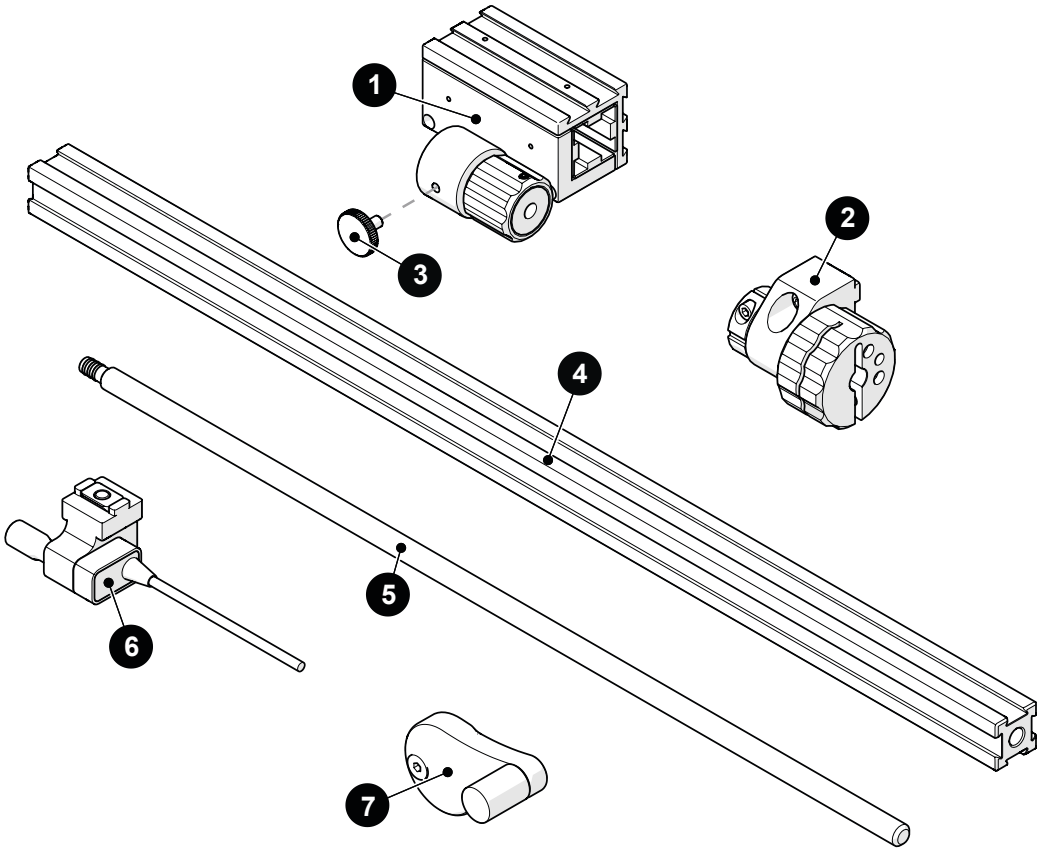

| BOM ID | Part # | Description |
|--------|--------------|------------------------------------|
| 1 | CJS008 | Slider |
| 2 | CJS001 | Slider PPS Main Knob |
| 3 | EA212 | Knurled Knob, M4 x 0.7 x 8 mm, SST |
| 4 | BG0038-X | Frame Bar (see Frame Bars) |
| 5 | CJS009-X | Slider PPS Encoded Leadscrew |
| 6 | CJS017-S-0.3 | Slider Index Encoder |
| 7 | CJS016 | Crank Handle |

Fig. 144 - Slider probe positioning system parts

NOTE: Additional leadscrew lengths available. (contact Jireh Industries Ltd. on page i)

6.4. Probe Holders

6.4.1. Slip Joint Probe Holder Parts

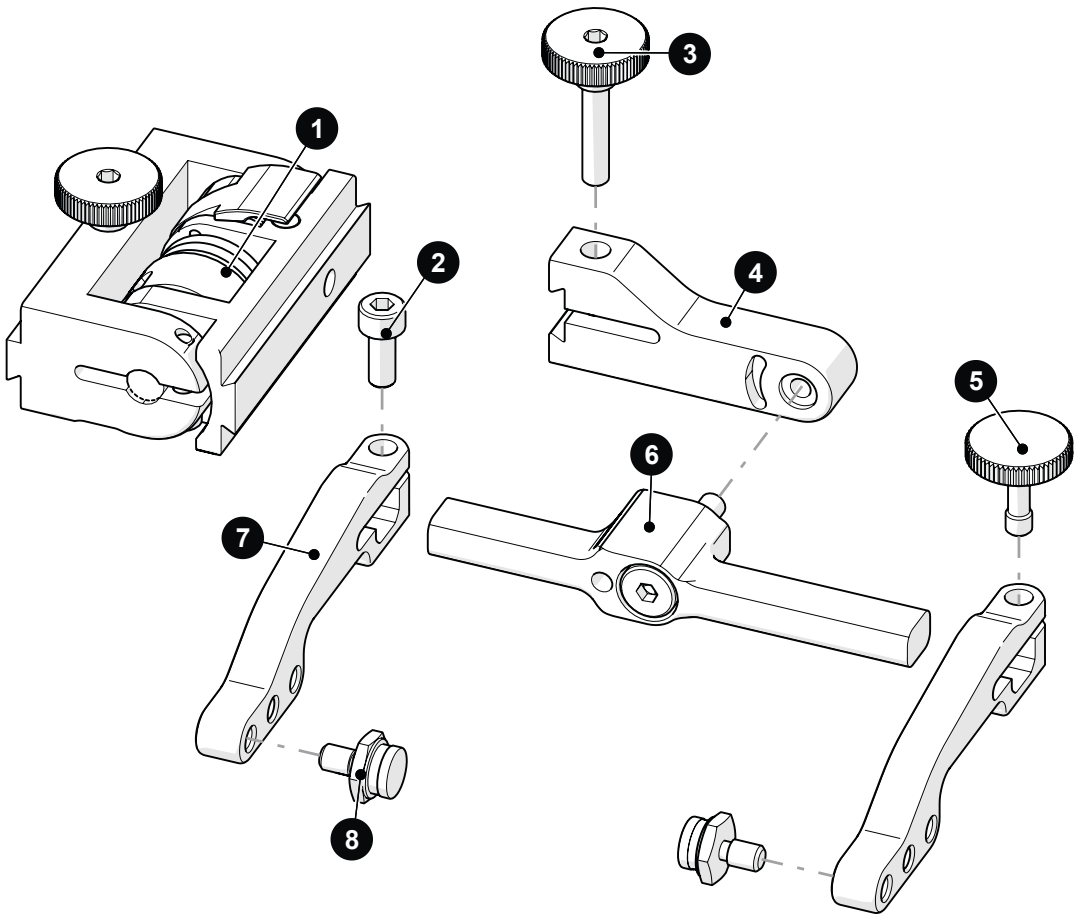

| BOM ID | Part # | Description |
|--------|-----------|---|
| 1 | PHS022 | Slip Joint Probe Holder Subassembly |
| 2 | MD050-010 | SHCS, M4 x 0.7 x 10 mm, SST |
| 3 | PH0104 | Knurled Knob, M4 x 0.7 x 18 mm, 4 mm stand off, SST |
| 4 | | see Swing Arm Style |
| 5 | PH0082 | Knurled Knob, M4 x 0.7 x 10 mm, 3 mm stand off, SST |
| 6 | | see Yoke Style |
| 7 | | see Arm Style |
| 8 | PH0011-X | Pivot Button Style (see Pivot Button Style) |

Fig. 145 - Slip joint probe holder parts

6.4.2. Vertical Probe Holder Parts

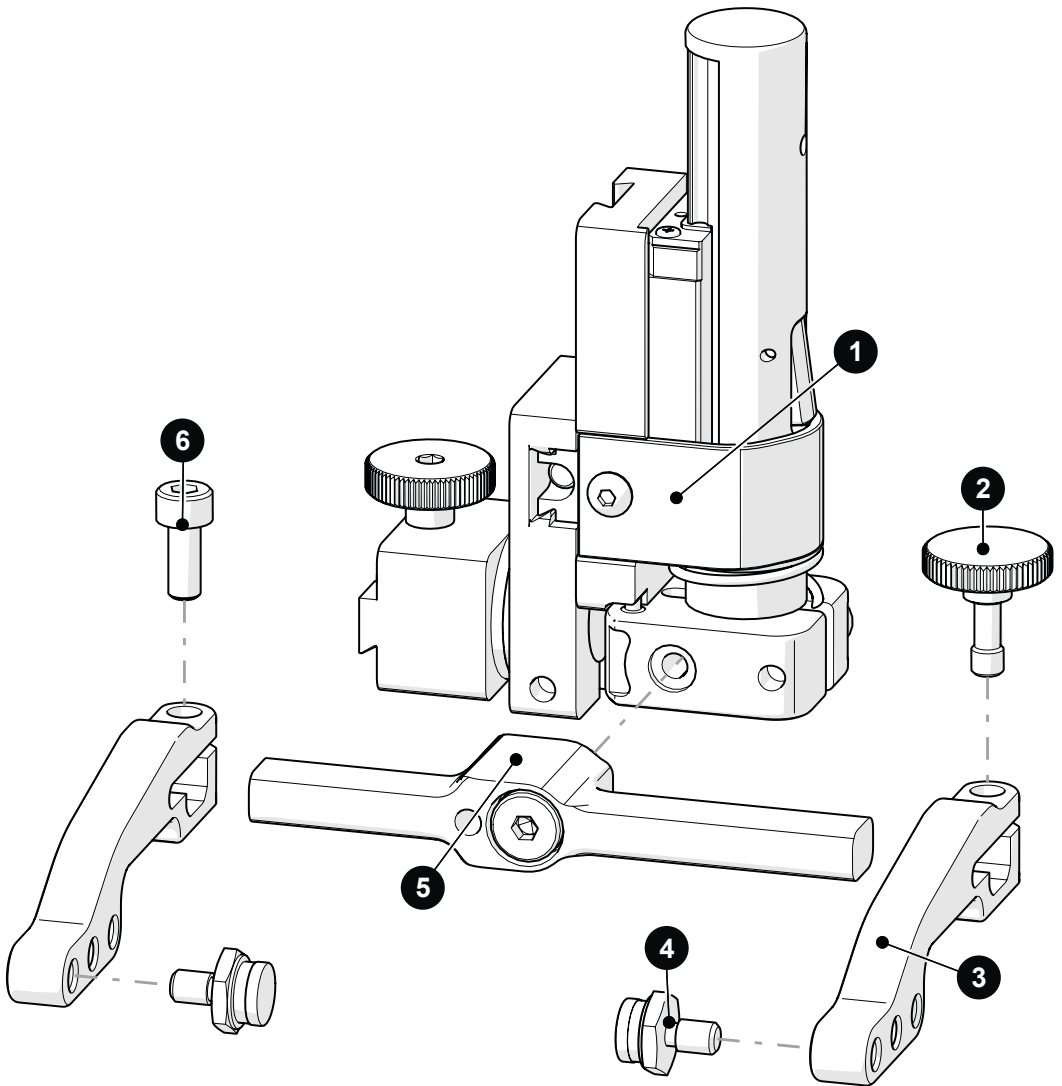

| BOM ID | Part # | Description |
|--------|-----------------------|--|
| 1 | PHS028 | Vertical Probe Holder Subassembly |
| 2 | PH0082 | Knurled Knob, M4 x 0.7 x 10 mm, 3 mm stand off, SST |
| 3 | <i>see Arm Style</i> | |
| 4 | PH0011-X | Pivot Button Style (<i>see Pivot Button Style</i>) |
| 5 | <i>see Yoke Style</i> | |
| 6 | MD050-010 | SHCS, M4 x 0.7 x 10 mm, SST |

Fig. 146 - Vertical probe holder

6.5. Probe Holder Components

6.5.1. Arm Style











| Arm Style | Part # | | Arm Style | Part # | | | |
|-----------|----------------------|--------|---|----------|-------------------|--------|--|
| A | Standard, Flat | PH0090 |  | B | Short, Flat | PH0089 |  |
| C | Long, Flat | PH0099 |  | D | Standard, Drop | PH0093 |  |
| E | Short, Drop | PH0092 |  | F | Long, Drop | PH0094 |  |
| G | Standard, Extra-Drop | PH0096 |  | H | Short, Extra-Drop | PH0095 |  |
| I | Extra-Short, Flat | PH0159 |  | J | Extra-Short, Drop | PH0161 |  |

Fig. 147 - Probe holder arm selection

6.5.2. Yoke Style

| Yoke Style | Part # | Length | | Yoke Style | Part # | Length | | | |
|------------|----------|--------|------------------|---|----------|--------|--------|------------------|--|
| S | Standard | PHS017 | 6.3 cm (2.47 in) |  | W | Wide | PHS027 | 7.9 cm (3.06 in) |  |

Fig. 148 - Probe holder yoke selection

6.5.3. Swing Arm Style



| Swing Arm Style | Part # | Length | | Swing Arm Style | Part # | Length | |
|-----------------|--------|------------------|---|-----------------|--------|------------------|---|
| Short | PH0069 | 4.1 cm (1.61 in) |  | Long | PH0100 | 4.6 cm (1.81 in) |  |

Fig. 149 - Swing arm selection

6.5.4. Pivot Button Style









| Pivot Hole Size | Wedge Type | | Pivot Hole Size | Wedge Type | | | |
|-----------------|------------------|------------------|---|------------|-------------------------|---------------|---|
| 01 | 8.0 mm (0.32 in) | Olympus PA |  | 02 | 5.0 mm (0.20 in) | Olympus TOFD |  |
| 03 | 2.7 mm (0.11 in) | Sonatest DAAH PA |  | 04 | 9.5 mm (0.38 in) | - |  |
| 06 | 3.0 mm (0.12 in) | - |  | 07 | 2.3 mm (0.09 in) | - |  |
| 08 | Conical Head | - |  | 09 | 5 mm (0.20 in) Internal | Zetec PA/TOFD |  |

Fig. 150 - Pivot button selection

NOTE: Additional probe holder pivot button types available.
(contact Jireh Industries Ltd. on page i)

6.6. Variable Components

6.6.1. Frame Bars











| Part # | Length | | Part # | Length | |
|-----------|------------------|---|-----------|------------------|--|
| BG0038-05 | 5 cm (1.97 in) |  | BG0038-10 | 10 cm (3.94 in) |  |
| BG0038-15 | 15 cm (5.91 in) |  | BG0038-20 | 20 cm (7.87 in) |  |
| BG0038-25 | 25 cm (9.84 in) |  | BG0038-30 | 30 cm (11.81 in) |  |
| BG0038-35 | 35 cm (13.78 in) |  | BG0038-40 | 40 cm (15.75 in) |  |
| BG0038-45 | 45 cm (17.72 in) |  | BG0038-50 | 50 cm (19.69 in) |  |
| BG0038-55 | 55 cm (21.65 in) |  | | | |

Fig. 151 - Frame bar selection

6.7. Accessories

6.7.1. Cable Management

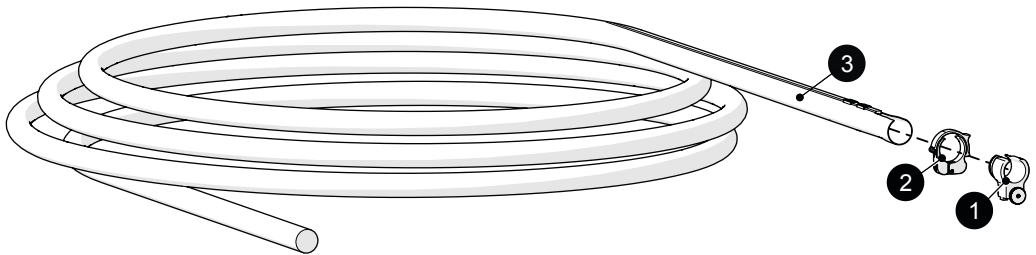

| BOM ID | Part # | Description |
|--------|--------|-----------------------------|
| 1 | CES067 | Cable Management Mount |
| 2 | CES066 | Cable Management Clamp |
| 3 | | See Cable Management Length |

Fig. 152 - Cable management

6.7.1.1 Cable Management Length

| Part # | Length |
|--------|-----------------|
| CX0141 | 4.5 m (14.7 ft) |
| CX0145 | 9.5 m (31.1 ft) |

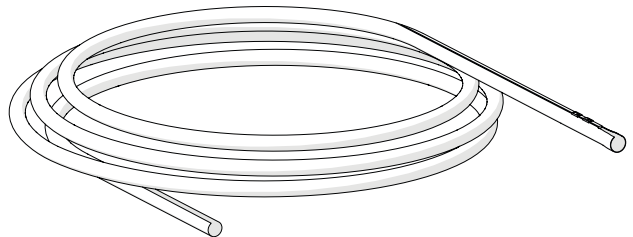
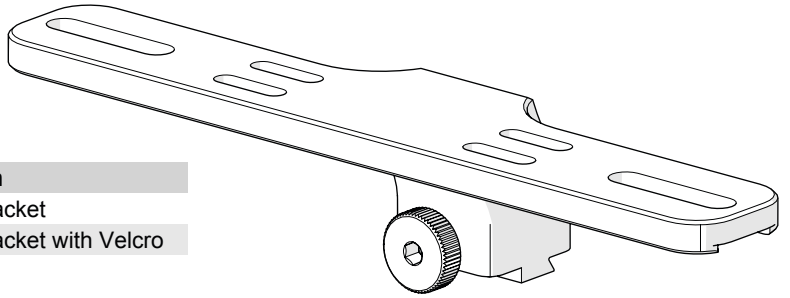

Fig. 153 - Cable management length

6.7.2. Pre-Amp Bracket



| Part # | Description |
|----------|-----------------------------|
| CES029 | Pre-Amp Bracket |
| CES029-V | Pre-Amp Bracket with Velcro |

Fig. 154 - Pre-amp bracket

6.7.3. Magnetic Wheel Kit

| Part # | Description |
|--------|--------------------|
| BTG014 | Magnetic Wheel Kit |

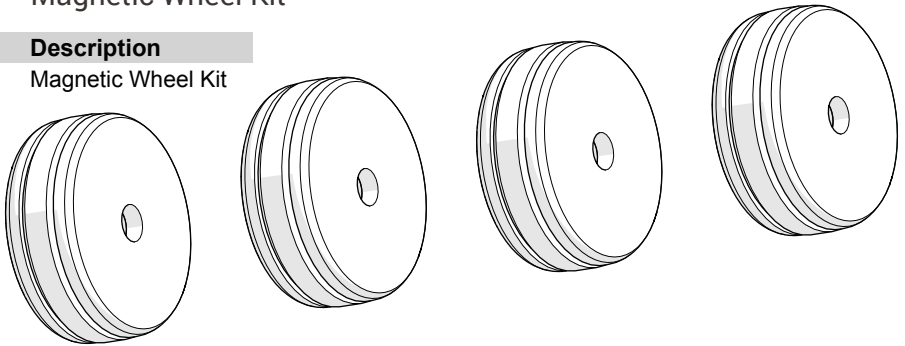
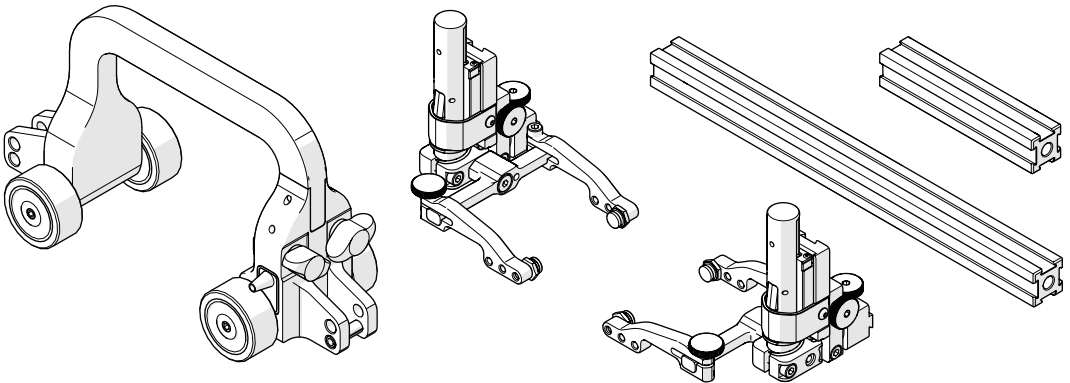

Fig. 155 - Magnetic wheel kit

6.7.4. Reduced Width Scanning Kit



| Part # | Description |
|-----------------|--|
| CEG018-W-XX-Y-Z | Reduced Width Scanning Kit, W - See 6.2.1, XX - See 6.5.3, Y - See 6.5.1, Z - See 6.5.2 |

Fig. 156 - Reduced width scanning kit

LIMITED WARRANTY

WARRANTY COVERAGE

Jireh Industries warranty obligations are limited to the terms set forth below: Jireh Industries Ltd. (“Jireh”) warrants this hardware product against defects in materials and workmanship for a period of THREE (3) YEARS from the original date of purchase. If a defect exists, at its option Jireh will (1) repair the product at no charge, using new or refurbished replacement parts, (2) exchange the product with a product that is new or which has been manufactured from new or serviceable used parts and is at least functionally equivalent to the original product, or (3) refund the purchase price of the product. A replacement product/part assumes the remaining warranty of the original product or ninety (90) days from the date of replacement or repair, whichever provides longer coverage for you. When a product or part is exchanged, any replacement item becomes your property and the replaced item becomes Jireh’s property. When a refund is given, your product becomes Jireh’s property.

OBTAINING WARRANTY SERVICE

To utilize Jireh’s warranty service you must ship the product, at your expense, to and from Jireh Industries. Before you deliver your product for warranty service you must phone Jireh and obtain an RMA number. This number will be used to process and track your product. Jireh is not responsible for any damage incurred during transit.

EXCLUSIONS AND LIMITATIONS

This Limited Warranty applies only to hardware products manufactured by or for Jireh Industries. This warranty does not apply: (a) to damage caused by accident, abuse, misuse, misapplication, or non-Jireh products; (b) to damage caused by service (including upgrades and expansions) performed by anyone who is not a Jireh Authorized Service Provider; (c) to a product or a part that has been modified without the written permission of Jireh.

Jireh Industries Ltd.
53158 Range Rd 224
Ardrossan AB T8E 2K4
Canada

Phone: 780-922-4534

Fax: 780-922-5766

jireh-industries.com

All brands are trademarks or registered trademarks of their respective owners and third party entities.

Changes or modifications to this unit or accessories, not expressly approved by the party responsible for compliance could void the user's authority to operate the equipment.

All specifications are subject to change without notice.

© 2015 Jireh Industries Ltd.



JIREH
SCANNING TECHNOLOGY FOR NDT

Jireh Industries Ltd.
53158 Range Road 224
Ardrossan, Alberta
Canada
T8E 2k4

780-922-4534

jireh-industries.com