

PTZ CAMERA SYSTEM // Ex RATED

VT 1000 PTZ - LASER HD Ex INSPECTION CAMERA

Watertight Full HD ExRated camera with pan and tilt function, zoom and integrated lighting. Integrated 2D/3D noise reduction and visibility enhancer provide perfect pictures even in difficult conditions.



LONG TERM LEASE



FEATURES

- Camera ATEX zone 1 rated (Ex II 2G Ex ib pxb IIC T6 Gb)
Camera IECEx rated (Ex eb ib pxb IIC T6 Gb)
- Zoom lens 30x optical / 12x digital
- 1080i/60 Full-HD resolution
- Radiation tolerant
- Integrated LED lighting
- Pan and tilt functions
- Watertight up to 50 m

APPLICATIONS

- All underwater inspections and monitoring applications
- Nuclear applications (refuelling – offloading – maintenance)
- Industrial applications
- Decommissioning applications

Contact us to find out more about the **VT 1000 PTZL HD Ex** or any of our other PTZ Camera Systems, or [request a quote online](#).

PTZ CAMERA SYSTEM // Ex RATED

VT 1000 PTZ - LASER HD Ex RATED INSPECTION CAMERA

TECHNICAL SPECIFICATIONS

ATEX zone	1
ATEX certification	Ex II 2G Ex ib pxb IIC T6 Gb (Camera) / Ex II 2G [Ex ib Gb] IIC (Box)
IECEX certification	Ex eb ib pxb IIC T6 Gb (Camera) / [Ex ib Gb] IIC (Box)
Image sensor	Full HD 1080p/60 fps with 1920 x 1080 resolution (Y/Pb/Pr output)
Zoom	30x optical / 12x digital
Field of vision	63.1° wide end – 2.3° tele
Focus	Auto or manual
Pan / tilt range	Infinite / 220°
Illumination	4 x LED spot
Line laser	Parallel line laser for measurement
Length / Diameter	250 mm / 135 mm
Weight	approx 5 kg.
Ambient temperature (TA)	+1°C to +50 °C
Pressure tight	1.5 bar / 21.8 psi
IP rating / Watertightness	IP 68 - 15 meters water depth
Cable length	50 meters standard / 100 meters on request

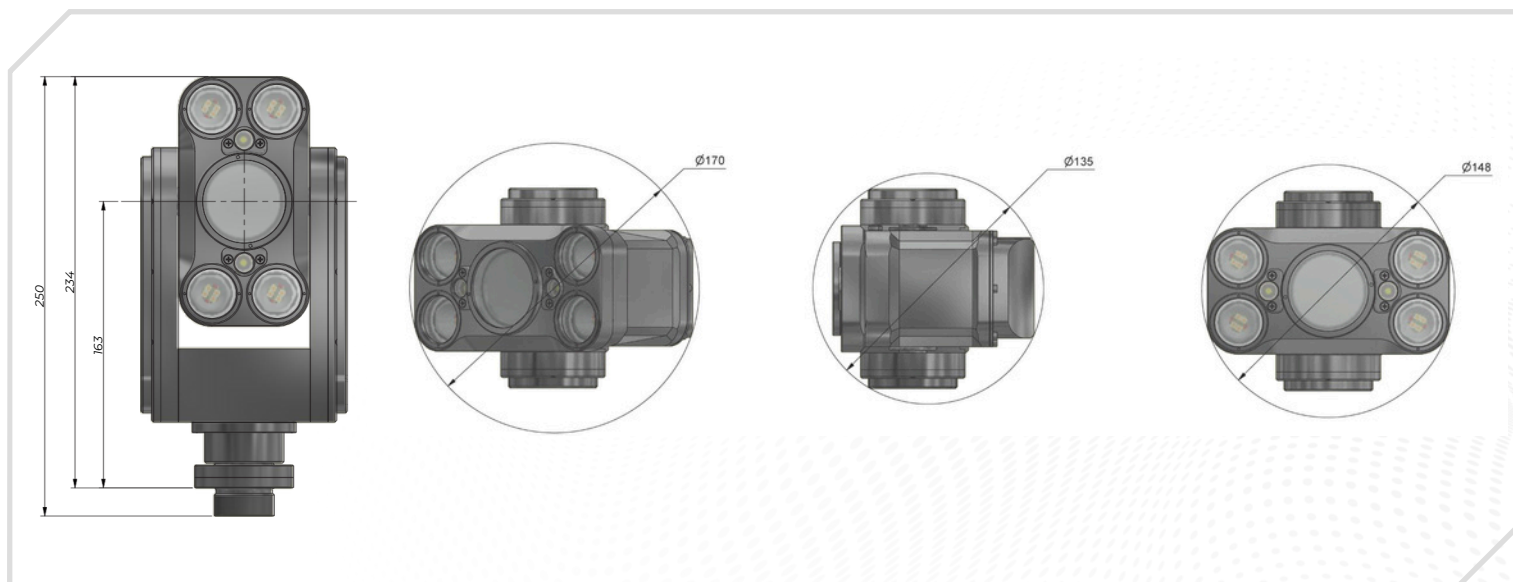

SETUP

Camera Calibration



VT 1000 PTZ - LASER HD Ex



VT 1000 HD SKT Ex



VT 1000 HD CON K



Control unit
VT 6360 CU



Control unit
VT 300-3 CU



Control unit
VT CamCtrl



VT 1000 Ex
Interface BOX



VT Nitrogen

Components - Ex camera system components not available individually



VT 1000 PTZ - LASER HD Ex
Full HD camera with 30x optical zoom, pan and tilt function and integrated lighting



VT 6360 CU
Portable CU with integrated 21.5" monitor, text inserter and recording functionality



VT 1000 Ex Interface BOX
Acts as the mediator between the Ex and non Ex part of the system



VT 1000 HD SKT Ex
Cable reel for VT 1000 Ex system with 50 meters of cable length



VT Nitrogen
Nitrogen purge system for periodic re-pressurisation of the camera body



VT 1000 HD CON K
Connects the CCU with the VT 1000 Ex Interface BOX

Optional accessories - not ATEX / EX classified



Carbon poles – 29 or 42 mm diameter
Carbon poles for deployment of cameras and tools



Manhole holders
Versatile positionner for 29 mm or 42 mm carbon poles