

PANTHER PIPE CRAWLER

Technical Specifications

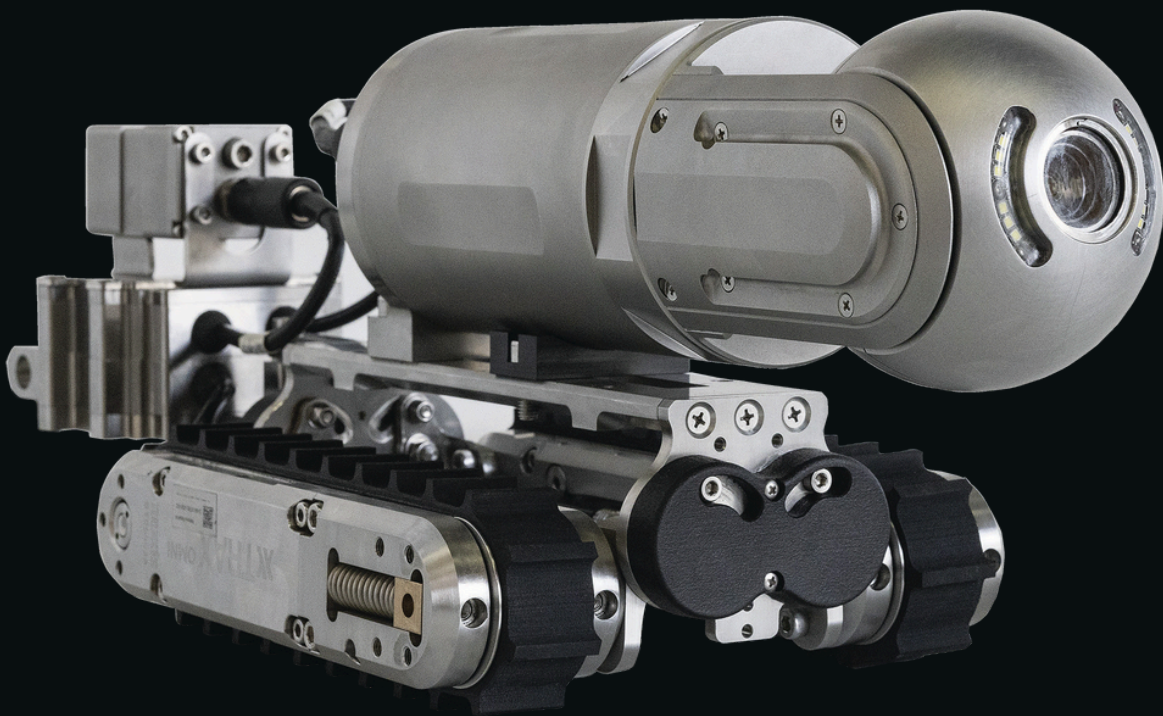

EASILY CUSTOMIZED WITH A RANGE OF EQUIPMENT

With a variety of configurations that can inspect almost any confined space or pipeline application.

Offering full modularity, the Panther series crawler can be equipped with a magnetic attachment for vertical and inverted travel on ferrous surfaces. Small size is a key feature with options that include multiple cameras, longer tethers, advanced reporting software and image enhancement systems for endless possibilities.

EASILY CUSTOMIZED WITH A RANGE OF EQUIPMENT

Capable of operating over long distances and a wide range of diameters, the Panther Pipe Crawler system is a state-of-the-art pipe inspection system with advanced capabilities. The system comes standard with a 100 m tether cable, with options for longer lengths available. Operators can examine pipes from 8" in diameter. The Panther comes with a full HD PTZ cameras with 4 LEDs.

Customizable with an array of optional equipment including retrieval tools, laser measurement & profiling systems and other Non-Destructive Testing (NDT) sensors. Nexxis designed software provides the operator with mouse and joystick controls for all vehicle functions. All sensor data is automatically logged during inspection operation and can be included with the final video (or images) using the intuitive reporting software.

INDUSTRIES

- Mining
- Utilities (Sewer / Water)
- Oil & Gas (Offshore / Onshore)
- Petrochemical
- Power Generation (Hydroelectric & Nuclear)

KEY APPLICATIONS

- Small Diameter pipelines
- Unpiggable pipelines
- Subsea vessel inspections
- Fresh water line
- Sewer systems
- FOSAR



JuiceBox Controller

Easily portable, this best-in-industry solution seamlessly connects and operates a range of HD or SD remote visual inspection cameras and equipment.



Panther with Scope HD

Fitted with the Scope HD camera which has pan, tilt and zoom, and driven by the aluminium XTRAX Omni, this configuration is a versatile inspection solution.



XTRAX Omni [Aluminium]

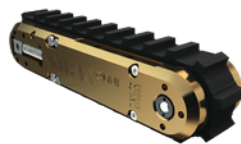

XTRAX Omni [Brass]



XTRAX Omni [Stainless Steel]

BUILD QUALITY OFFERS UNSURPASSED RELIABILITY



PANTHER PIPE CRAWLER SPECIFICATIONS

INTERNAL PIPE SIZE	Minimum	205 mm (8"0)
	Maximum	Flat (180°)
EXTERNAL PIPE SIZE	Minimum	500 mm / 19.68 in
TETHER LENGTH	100 m (328 ft) standard	
CAMERAS	Front & Rear, multiple range of HD options	
WEIGHT	From 6.8 kg / 15 lbs (depending on material and accessories) 9 kg / 19.8 lbs	
PULLING CAPACITY		
PAYLOAD	16 kg / 35.7 lbs	
TEMPERATURE RATING	Standard	0 - 50 °C / 32 - 122 F
DEPTH RATING	Standard	Up to 150 m / 492 ft
MATERIAL OPTIONS	Aluminium, Stainless Steel, Other custom options	
CONTROL SYSTEM	Power Supply	110 - 240 V AC, 500 W
	Controller	JuiceBox

CAMERA SPECIFICATIONS

Aluminium anodized, high-resolution camera for detailed imaging with integrated LED lighting and pan & tilt function.	
ZOOM LENS	10x Optical / 12x Digital
DEPTH RATING	60 m -150 m / 196.85 - 492.12 ft
LIGHTS	4x High Intensity LED Floods built into camera
TEMPERATURE RATING	0 - 50 °C / 32 - 122 F
WEIGHT	3 kg / 6.6 lbs

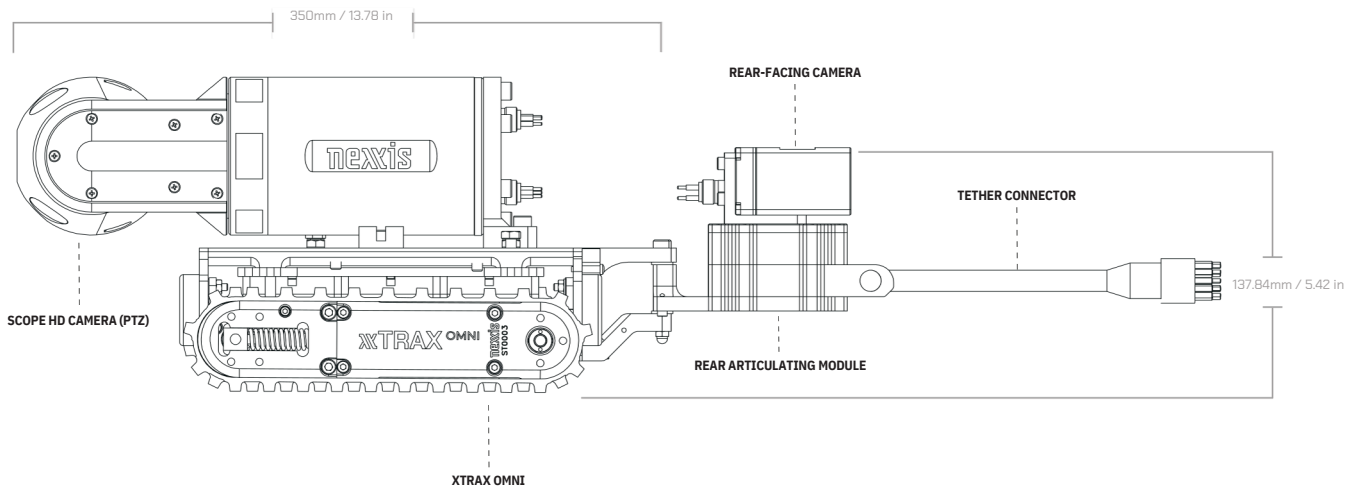
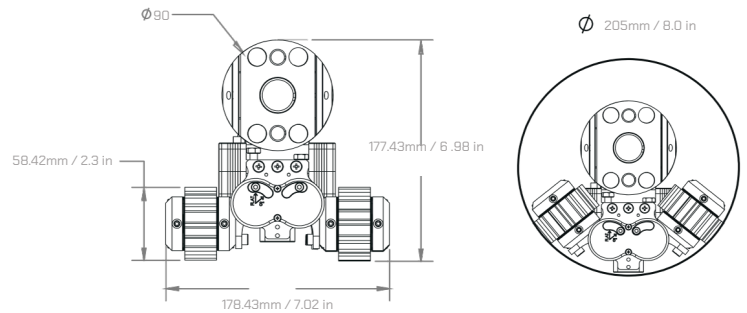

HOUSTON

315 Odyssey, Suite D
Webster, TX 77598
United States
Ph: +1 (713) 258-6061

AUSTRALIA

35 Peel Road
O'Connor, WA 6163
Australia
Ph: +61 (08) 9418 4952

SINGAPORE

37 Jalan Pemimpin
#03-02 MAPEX
Singapore 577177
Ph: +65 3158 0269

[GET IN CONTACT](#)