

VETOL

Technical Specifications

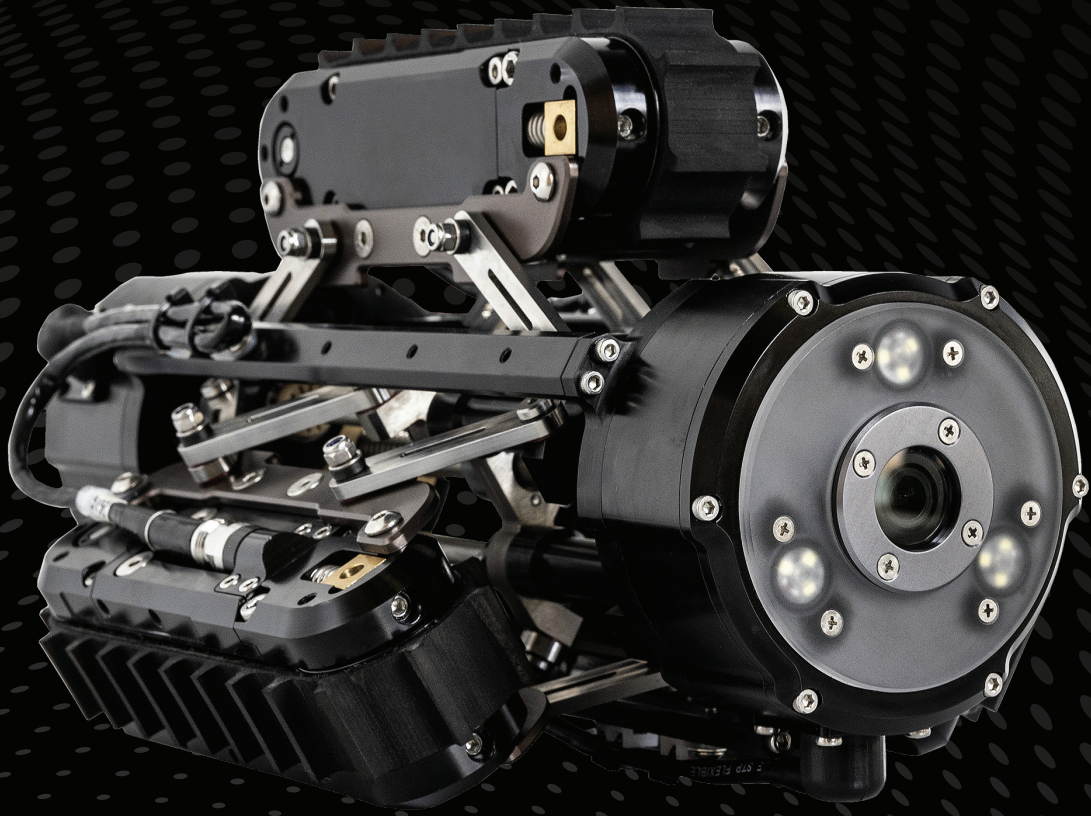

VETOL S

Designed and developed with the end user in mind, VETOL is suitable to integrate with an array of payloads. Capable of navigating vertical pipelines with either tracked configuration VETOL is ready for any challenge.

Utilizing fiber optic technology for steadfast long-distance stability, thereby facilitating ample bandwidth for seamless power and communication delivery, the VETOL proves versatile across diverse applications. VETOL is further enhanced with the customization of the XTRAX material in either Steel, Aluminium or Brass

INTUITIVE CONTROL SYSTEM

Nexxis designed software (with no ongoing subscription fees) provides the operator with mouse and joystick controls for VETOL functions allowing complete remote operation of the system. All sensor data is automatically logged during an inspection, and can be included with the final video (or still images) using the NCS 2.0 reporting software.

MODULAR CONFIGURATIONS

All of our dedicated systems, are easily customized with an array of optional equipment including high- definition pan-tilt-zoom cameras, retrieval tools, laser measurement, profiling systems, sonar and other Non-Destructive Testing (NDT) sensors. Multiple tooling, surface preparation and cleaning payloads can also be fitted.

INDUSTRIES

- Oil & Gas (Onshore & Offshore)
- Utilities (Sewer / Water)
- Petrochemical
- Energy
- Power Generation
- Hydroelectric / Nuclear
- Mining

KEY APPLICATIONS

- Pipelines / Unpiggable Pipelines
- Process Pipe
- Tunnels
- Sewer
- Waterlines (Waste & Potable)



JuiceBox Controller

Easily portable, this best-in-industry solution seamlessly connects and operates a range of HD or SD remote visual inspection cameras and equipment.



VETOL S

Fitted with a front and rear-facing camera and the XTrax Omni Aluminium, this VETOL is a light-weight, durable and versatile solution ideally suited to rapid, high-quality inspections.



XTRAX Omni (Aluminium)

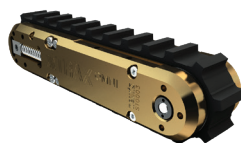

XTRAX Omni (Brass)



XTRAX Omni (Stainless Steel)

REACHING NEW HEIGHTS WITH VETOL S

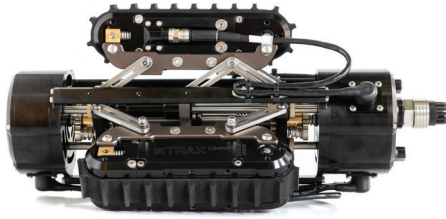

VETOL PIPE CRAWLER SPECIFICATIONS

PIPE DIAMETER	20.3cm / 8.0in
DEPTH RATING	60m / 196.85ft standard
STANDARD TETHER LENGTH	100m / 328.1ft standard
MAXIMUM SPEED	9m / 30ft per minute
COMMUNICATION PROTOCOL	Ethernet over Fiber Optics
OPERATING TEMPERATURE	0°-45° C / 32°-113° F
OPERATING VOLTAGE	48 - 72 Vdc
VEHICLE WEIGHT	7.5kg / 16.5lbs
VEHICLE DIMENSIONS	376mm (L) x 203.3mm (d) / 14.8in (L)x 8in (d)
STANDARD COMPONENTS	Nexxis Fiber-Optic Reel Juicebox Controller XTRAX Omni

PUSHING THE LIMITS OF VERTICAL INSPECTION

The VETOL is a versatile and configurable vertical inspection solution that provides high-quality data when it counts. Equipped with an in-built rear-facing camera and LED lights in addition to the front facing HD inspection camera - capturing precise, reliable visual data has never been easier.



20.3 - 25.4cm / 8 - 10 in

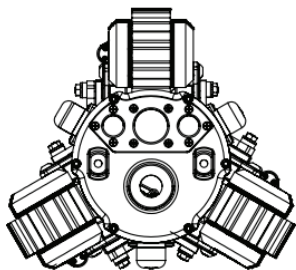

BACK CAMERA

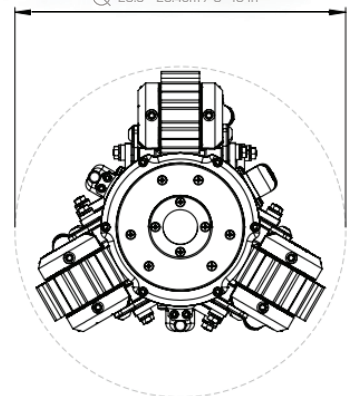
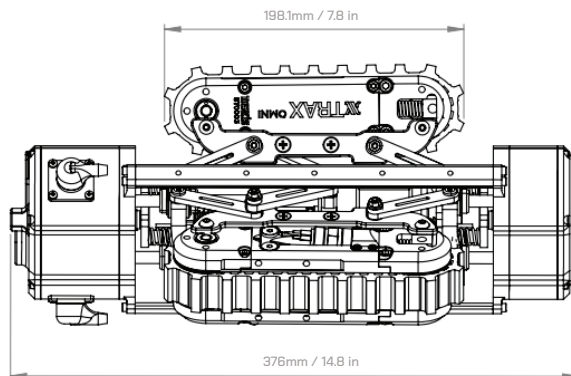

VER 1.0

35 Peel Road,
O'Connor 6163,
Western Australia

315 Odyssey Dr.
Suite D
Webster, TX 77598

37 Jalan Pemimpin
#03-02 Mapex
Singapore, 577177

HOUSTON

315 Odyssey, Suite D
Webster, TX 77598
United States

Ph: +1 (713) 258-6061

AUSTRALIA

35 Peel Road
O'Connor, WA 6163
Australia

Ph: +61 (08) 9418 4952

SINGAPORE

37 Jalan Pemimpin
#03-02 MAPEX
Singapore 577177

Ph: +65 3158 5772

[GET IN CONTACT](#)