

VT 70 PTZ SD camera system brochure



VT 70 PTZ(L) SD camera system

Compact and watertight camera with pan-tilt function and integrated LED lighting and optional line laser

Applications

- > All underwater inspections and monitoring applications in hard to reach areas
- > Nuclear applications - e.g. pressure vessel inspections
- > Industrial applications e.g. deep well inspections
- > Decommissioning applications - e.g. pipe and tank inspections

Features

- > Robust and compact design
- > Zoom lens 10x optical / 16x digital
- > High-resolution camera for detailed pictures
- > Integrated LED lighting
- > Pan and tilt functions
- > Watertight
- > Slipping clutch



Technical specifications - VT 70 PTZ(L) SD camera

This document is for general information only, please consult the system manual for detailed specifications

Material	Anodized aluminium	
Image sensor	1/3" CMOS Sensor (app. 4 MPixel)	
Resolution	600 lines	
Video out	CVBS / PAL-NTSC	
Zoom	10x optical / 16x digital	
Field of vision	59.2° (Wide) - 6.7° (Tele)	
Focal length	3.3mm - 33mm (f/1.8 - F3.4)	
Minimum distance lens	5cm (1.96")	
White balance	manual	
Range - Pan	infinite	
Range - Tilt	270° with position feedback encoder	
Lighting	9 x 3 W LED	
Dimensions	PTZ / PTZL	L x Ø = 217 / 225mm x 70mm (8.54 / 8.86" x 2.76")
Weight	PTZ / PTZL	approx. 1507 / 1591g (3.3 / 3.5lbs)
Operating temperature	0°C to +50°C (32°F to 122°F)	
Watertight	5 bar (72.5 psi) / 50m (164ft)	
Radiation resistance	5500 rad/h (55Gy/h) / total 40.000 rad (400 Gy)	
Laser / laser class / line distance	2 line laser, wavelength 650nm / class 1 / approx. 12mm	

* unit in mm

VT 70 PTZ SD

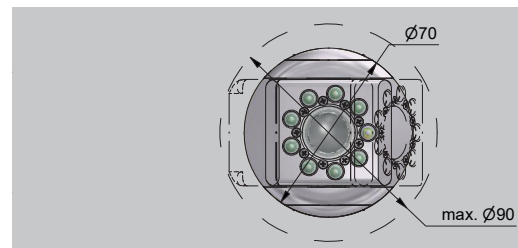
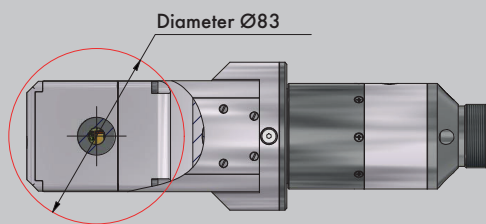
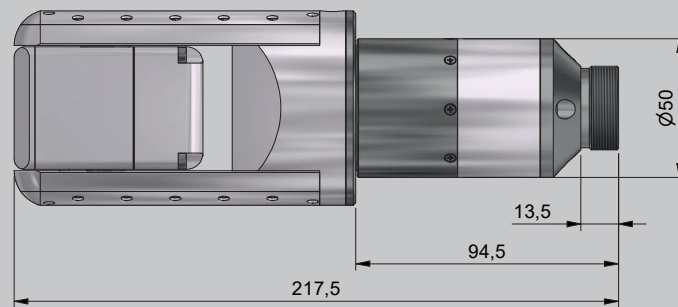

VT 70 PTZL SD

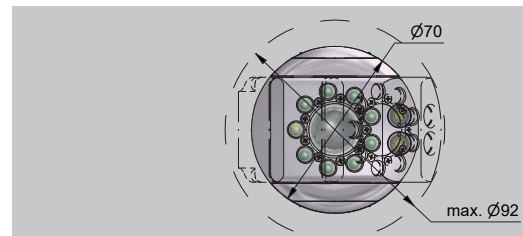
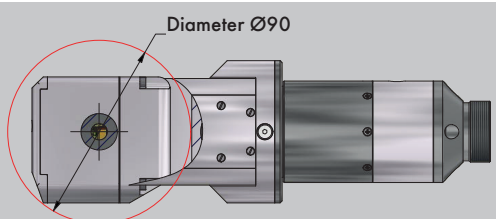
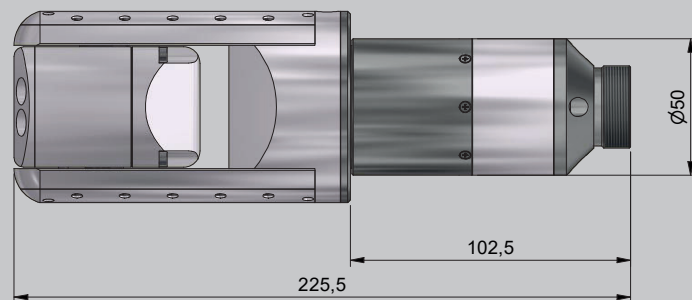

1 Camera



VT 70 PTZ(L) SD

2 Cabling



VT 780 SKT



VT 72 HD SKT

3 Control unit



Control unit
VT 6360 CU



Control unit
VT CamCtrl



Control unit
VT 300-3 CU



Remote control
VT 780-2 FB

Components, related products - and accessories



VT 6360 CU

Portable CU with integrated 21.5" monitor, text inserter, recording functionality and removable remote control



VT 300-3 CU

Rack mountable or standalone control unit in 19-inch case for different camera series

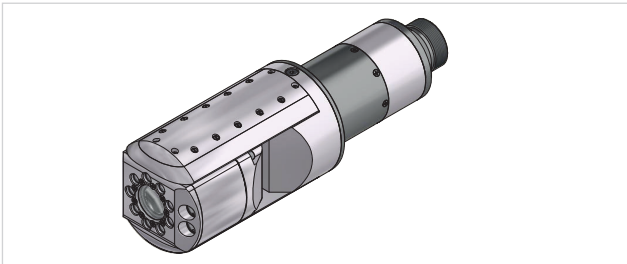

VT 70 PTZ(L) SD

The VT 70 PTZ(L) SD camera also has two line lasers with a defined distance.

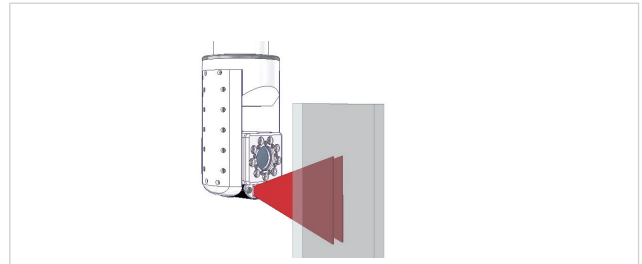

Laser module

Laser generator to display reference lines for measurement software

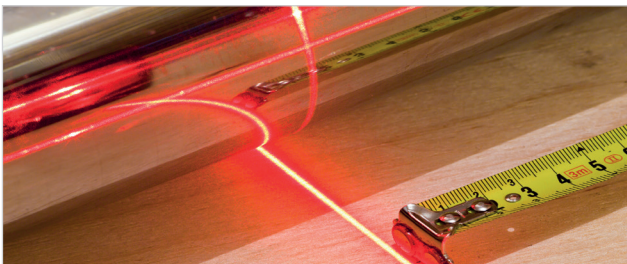

VIAS - Measurement software

Software to calculate lengths of inspected objects, e.g. scratches (alu body only)



VT 780 SKT cable reel with wheels

Reel equipped with kevlar reinforced cable and extendable arm

Optional accessories



VT 29 Carbon poles - 29 or 42mm diameter

Carbon poles for deployment of cameras and tools



VT GH Vario tool holder with pole adaptor

Variable rail holder with stainless steel pole adaptor to connect the camera to carbon poles - 29 or 42mm diameter

Nexxis Australia

35 Peel Road, O'Connor, WA, 6164
Tel. +61-8-9418 4952
www.nexxis.com.au

Nexxis America

315 Odyssey Drive, Suite D, Webster, TX 77598
Tel. +1 (713) 258 6061
www.nexxis.com

nexxis

DEKRA

On the safe side.