

# VT 34 PT camera system brochure



## VT 34 PT / (VT 34 TBM4 optional) pan and tilt camera

Extremely compact and watertight camera with pan and tilt function and integrated lighting, diameter 34 (36)mm

### Applications

- > All visual inspections and monitoring applications
- > Nuclear, oil & gas, chemical and petrochemical inspections
- > Industrial applications

### Features

- > Small, robust and modular design
- > Lens 5.0mm
- > 600 lines resolution
- > Acrylic glass cover dome
- > Integrated LED lighting
- > Pressure tight up to 5 bar / 72.5 psi



## Technical specifications - VT 34 PT camera

This document is for general information only, please consult the system manual for detailed specifications

Material housing		Stainless steel (1.4305)
Material cover dome		Acrylic glass
Image sensor		1/3" CCD
Resolution		600 lines
Video out		CVBS / PAL-NTSC
Zoom		No
Focal length		5mm (f/3.8)
Focus		5mm - infinity
Focus control		manual
Range - pan		infinite
Range - tilt		210°
Lighting		LED 9 x 3000mcd / 120° / cold-white
Dimensions	VT 34 PT / VT 34 TBM4	L x D = 90 x 34mm (3.5" x 1.3") / L x D = 91 x 36mm ( 3.6" x 1.4")
Weight	VT 34 PT / VT 34 TBM4	150g (0.33lbs) / 180g (0.40lbs)
Operating temperature		-15°C to +50°C (5°F to 122°F)
Watertight	VT 34 PT / VT 34 TBM4	up to 5 bar (72.5 psi), 50m (164ft) / 50 bar (725 psi), 500m (1640ft)
Radiation resistance		3300 rad/h (33Gy/h)
Total		43.000rad (430 Gy)

\* unit in mm

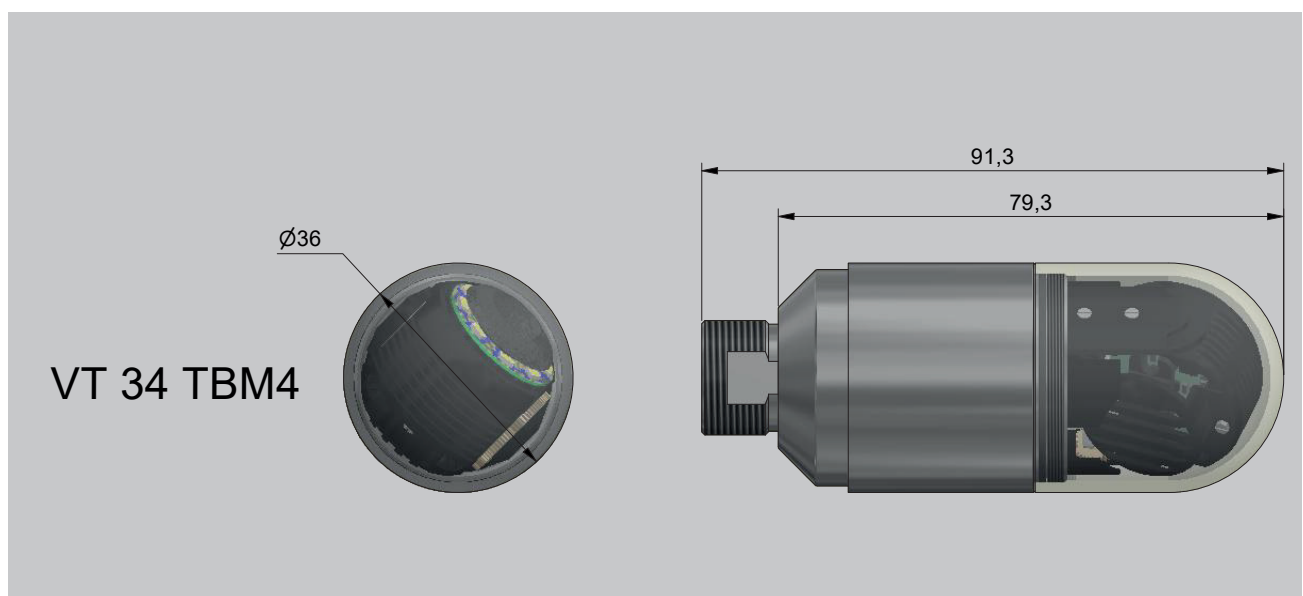
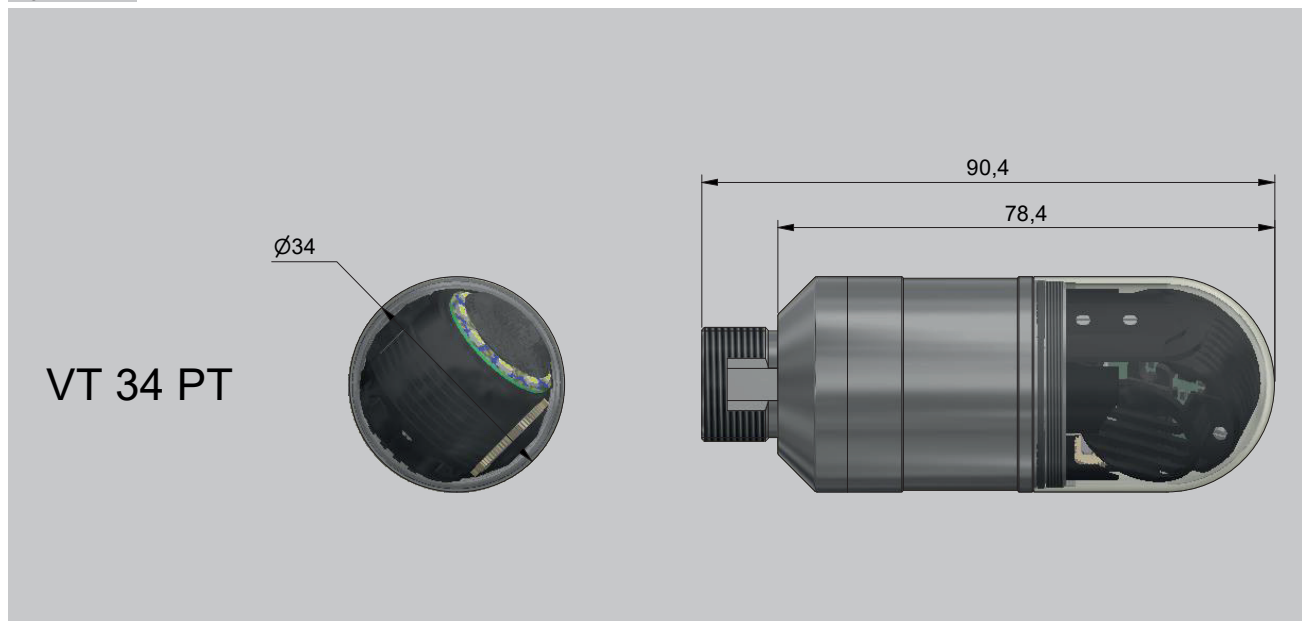

# 1 Camera



VT 34 PT /  
VT 34 TBM4

# 2 Cabling



VT 34 SKT

# 3 Control unit



Control unit  
VT 34 CU



Control unit  
VT 334 FWSD CU



Control unit  
VT CamCtrl



Control unit  
VT 300-3 CU



Remote control  
VT 34 FB



## Components, related products - and accessories



### VT 34 CU

Compact control unit for VT 34 /VT 34 TBM4 cameras with optionally integrated text inserter



### VT 334 FWSD CU

Compact control unit with integrated Full-HD monitor in watertight PeliCase



### VT 6360 CU

Portable CU with integrated 21.5" monitor, text inserter and recording functionality



### VT 300-3 CU

Rack mountable or standalone control unit in 19-inch case for different camera series



### VT 34 FB

Remote control to operate a VT 34 PT camera on a VT 300-3 control unit

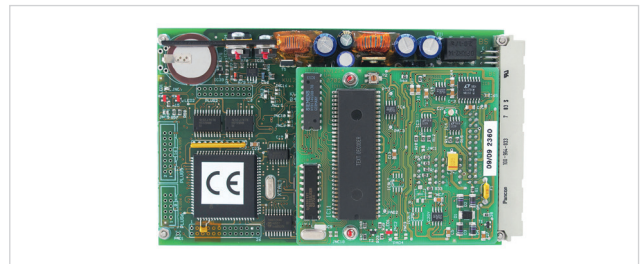

### VT KV1214

Video insertion system V-EBS for text and information display

## Optional accessories



### Carbon pole - 29mm diameter

Carbon pole for deployment of cameras and tools

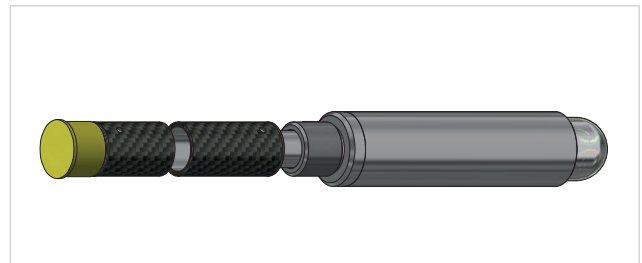

### VT 34 PT Holder

Carbon pole with quick release coupling to adapt the camera

### Nexxis Australia

35 Peel Road, O'Connor, WA, 6164  
Tel. +61-8-9148 4952  
www.nexxis.com.au

### Nexxis America

315 Odyssey Drive, Suite D, Webster, TX 77598  
Tel. +1(713) 258 6061  
www.nexxis.com

nexxis

DEKRA

On the safe side.